

MARINE FENDERS

IRM MARINE FENDERS

IRM offers the widest range of fenders to suit almost all kinds of berths and berthing methods in various climatic and site conditions. We manufacture the entire range of solid as well as floating (pneumatic, foam & hydro pneumatic) fenders to accommodate berthing requirements of the smallest fishing boats to ULCCs and VLCCs for jetty as well as ship to ship operations. Our fenders are renowned for their long and trouble-free service life without deterioration in its performance and characteristics. They are the last word in reliability and safety and are preferred worldwide where critical applications are envisaged.

Custom-made designs of IRM fenders offer greater economy while conforming to the international specifications and operational requirements. Today, IRM is synonymous with the high quality precision moulded rubber fenders for ports and harbors.

IRM fenders are manufactured by compression moulding process at very high pressure up to 2000 tons load, which is much better and advanced technology than the ancient extrusion process, resulting in zero porosity / bubble free moulding of fenders. Fenders are manufactured from different type of rubber compound according to the berthing energy requirements & site conditions. These compounds are made of purest form of natural rubber, high abrasion resistant synthetic rubbers like Neoprene, SBR, EPDM, having excellent U.V resistance, resistance to ozone aging, resistance to sea water etc. They can withstand extreme climate conditions from very low ambient temperature to very high ambient temperature prevailing in various locations across the globe.



Proud of our past. Focused for better future.



CONTENTS.

Introduction	1
Multipurpose Fenders	
Cylindrical Fenders	3
Correction Factors For Cylindrical Fenders	7
Arch Fenders	8
DA Series	9
DYNA Arch Fender - DYA Series	11
DAV Series	13
DAVP Series	15
Flat Top Arch Fender - DFTA Series	17
DAFB Series	19
Correction Factors For DFTA Series	20
W Fenders - DW Series	21
DDA Fenders - A, B & C Series	24
Element Fender Series	25
DI Series	27
DIV Series	29
DIVE Series	31
DIVSE Series	33
DIVM Series	35
Correction Factors For Element Fenders	37
High Performance Fenders	38
Cell Fenders - DC Series	39
Correction Factors For Cell Fender	44
Cone Fenders - DCN Series	45
Correction Factors For Cone Fender	50
Roller Fenders	51
DRF Series	53
DR Series	55
Fender Testing	57
Fendering System Design Data Sheet	58
Technical Specification of Rubber	60
Conversion Table	61
Photo Gallery	62

CYLINDRICAL FENDERS - DCY SERIES

IRM DCY series Cylindrical Fenders are commonly used and are recommended for all types of applications to ensure safe berthing for various vessels. Ideal for a terminal offering a wide range of berthing facilities for ships of varying sizes as these fenders have lower reaction force to smaller ships.

Key attributes :

- Economical solution to protect most berthing structures
- Linear load-deflection curve
- Less reaction force at lower deflection
- Easy to install and maintain

Range :

Cylindrical Fenders are available in a wide range from 150 mm outer diameter to 3000 mm outer diameter in 2 - 3 meters length or more for special requirements.

Applications :

- Bulk cargo berths
- Fishing and workboat berths
- General cargo quays
- Pontoons and floating structures
- RoRo and ferry terminals
- Tugboats

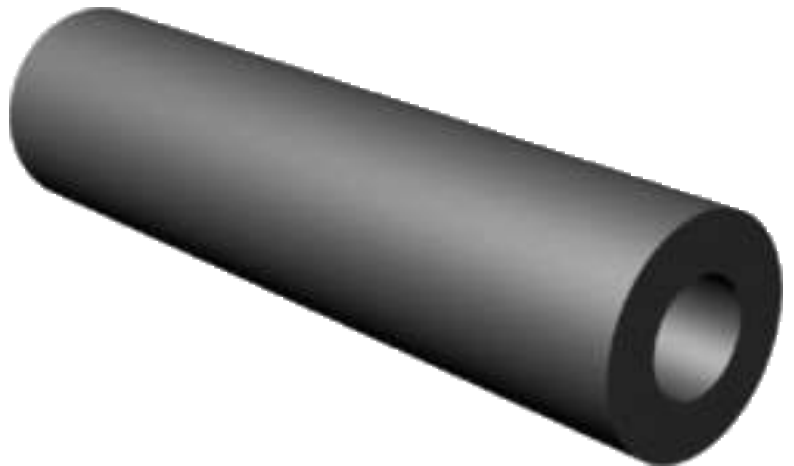

TYPICAL FIXING ARRANGEMENT

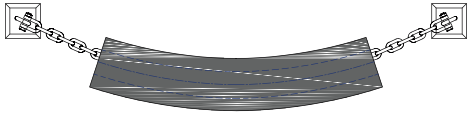
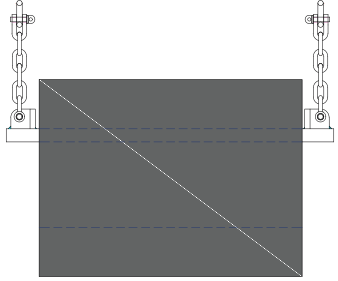
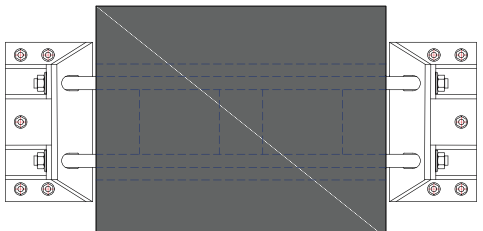
<p>TYPE – I : For small cylindrical fenders, suspended by a single chain. Generally recommended for sizes below 600 mm OD.</p>	
<p>TYPE – II : For large cylindrical fenders, hanging on a solid rod or a pipe, supported with two chain assemblies. Generally recommended for size over 600 mm OD up to 1500 mm OD.</p>	
<p>TYPE – III : For extra-large cylindrical fenders, which requires heavy support system. Fenders are supported on a ladder type assembly fabricated from solid rod or pipes, which are fixed on heavy duty side brackets. Generally recommended for sizes over 1500 mm OD up to 3000 OD.</p>	

Note : Above fixing arrangements can be modified to suit site requirements. Such arrangements shall be specifically designed for cases to case basis.

CYLINDRICAL FENDERS - DCY SERIES



PHOTOS OF TESTING



CYLINDRICAL FENDERS - DCY SERIES

DIMENSION TABLE

ALL DIMENSIONS ARE IN MM

MODEL	Ø D	Ø d	APPROX. WEIGHT Kgs. / Mtr.
DCY 150	150	75	18
DCY 200	200	100	31
DCY 250	250	125	48
DCY 300	300	150	69
DCY 350	350	175	94
DCY 400	400	200	123
DCY 500	500	250	192
DCY 600	600	300	276
DCY 700	700	350	375
DCY 800	800	400	490
DCY 900	900	450	620
DCY 1000	1000	500	766
DCY 1100	1100	550	927
DCY 1200	1200	600	1103
DCY 1300	1300	650	1295
DCY 1400	1400	700	1501
DCY 1500	1500	750	1725
DCY 1600	1600	800	1960
DCY 1700	1700	850	2212
DCY 1800	1800	900	2480
DCY 1900	1900	950	2764
DCY 2000	2000	1000	3062
DCY 2100	2100	1050	3376
DCY 2200	2200	1100	3705
DCY 2300	2300	1150	4050
DCY 2400	2400	1200	4409
DCY 2500	2500	1250	4784
DCY 2600	2600	1300	5174
DCY 2700	2700	1350	5580
DCY 2800	2800	1400	6001
DCY 2900	2900	1450	6437
DCY 3000	3000	1500	6890

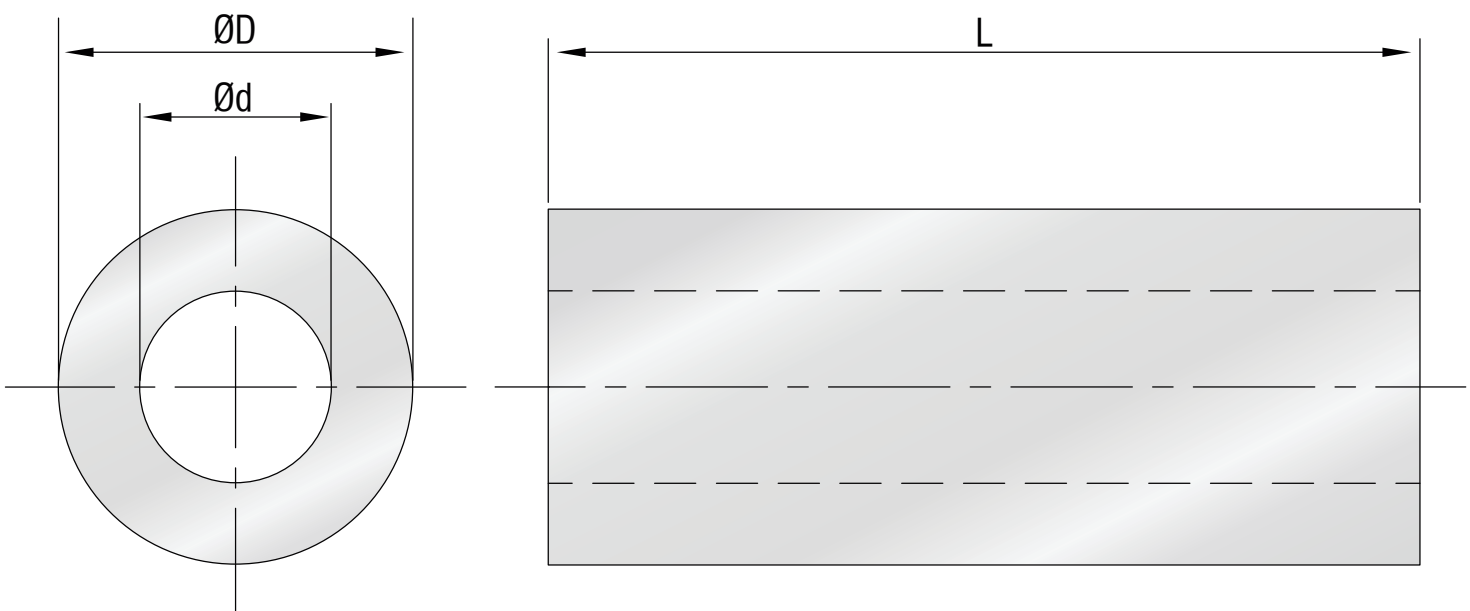

CYLINDRICAL FENDERS - DCY SERIES

PERFORMANCE TABLE (Performance of Unit Length)

GRADE	R1.0		R1.1		R1.2		R1.3		R2.0		R2.1		R2.2		R2.3		R3.0	
DEFLECTION	50%		50%		50%		50%		50%		50%		50%		50%		50%	
	E	R	E	R	E	R	E	R	E	R	E	R	E	R	E	R	E	R
MODEL																		
DCY 150	2.6	95.3	2.4	91.0	2.3	86.5	2.2	82.1	2.1	77.7	1.8	67.8	1.5	57.8	1.2	47.9	1.0	37.9
DCY 200	4.8	127.7	4.6	121.8	4.3	115.7	4.1	109.7	3.9	103.6	3.4	90.3	2.9	76.8	2.3	63.4	1.8	50.0
DCY 250	7.5	159.2	7.1	151.8	6.8	144.4	6.4	137.0	6.1	129.6	5.3	112.9	4.6	96.3	3.7	79.6	2.9	62.9
DCY 300	10.8	191.6	10.4	182.7	9.9	173.5	9.4	164.6	8.8	155.5	7.7	135.4	6.5	115.2	5.3	95.2	4.3	75.0
DCY 350	14.8	223.1	14.1	212.8	13.4	202.3	12.7	191.9	12.0	181.5	10.4	158.1	8.9	134.7	7.3	111.4	5.7	87.9
DCY 400	19.8	254.5	18.9	242.9	17.9	231.0	17.0	219.2	16.1	207.4	14.0	180.5	11.9	153.6	9.9	126.8	7.7	100.0
DCY 500	30.3	318.5	28.9	303.7	27.4	288.9	26.0	274.1	24.6	259.2	21.4	225.7	18.2	192.1	15.1	158.5	11.8	125.0
DCY 600	43.5	382.3	41.4	364.6	39.4	346.7	37.4	329.0	35.4	311.0	30.7	270.8	26.2	230.5	21.6	190.2	17.0	150.0
DCY 700	55.6	445.3	53.0	424.8	50.5	404.1	47.9	383.6	45.3	362.9	39.4	315.9	33.6	269.0	27.7	222.0	21.8	174.9
DCY 800	77.3	509.2	73.7	485.6	70.2	461.9	66.5	438.4	63.0	414.8	54.8	361.0	46.6	307.4	38.5	253.7	30.4	199.9
DCY 900	97.6	574.0	93.3	548.5	89.0	523.0	84.7	497.6	80.4	472.1	69.8	410.4	59.3	348.6	48.8	286.8	38.2	224.9
DCY 1000	120.9	638.9	115.2	608.8	109.5	578.6	103.8	548.5	98.1	518.4	85.4	451.4	72.7	384.2	60.0	317.1	47.3	249.9
DCY 1100	145.9	703.7	139.2	671.2	132.4	638.9	125.8	606.4	119.0	574.0	103.5	499.3	88.0	424.5	72.5	349.8	57.0	274.9
DCY 1200	173.2	768.4	165.4	733.7	157.5	699.0	149.8	664.3	142.0	629.5	123.3	547.2	104.8	464.8	86.2	382.3	67.6	299.9
DCY 1300	204.0	833.2	194.4	793.9	184.7	754.6	175.1	715.3	165.5	675.8	144.0	588.2	122.5	500.4	101.1	412.7	79.6	324.9
DCY 1400	236.3	898.0	225.4	856.4	214.4	814.8	203.4	773.1	192.5	731.4	167.4	636.0	142.2	540.7	117.1	445.3	92.0	350.0
DCY 1500	272.5	953.7	259.9	909.6	247.4	865.7	234.8	821.7	222.3	777.7	193.4	677.1	164.7	576.3	135.9	475.7	107.1	375.0
DCY 1600	309.3	1018.5	295.2	972.2	281.1	925.9	267.1	879.5	253.1	833.2	220.1	725.0	187.3	616.6	154.3	508.2	121.5	400.0
DCY 1700	348.5	1083.3	332.8	1034.7	317.2	986.0	301.5	937.5	285.9	888.8	248.7	772.9	211.3	656.9	174.0	541.0	136.7	425.0
DCY 1800	391.4	1148.0	373.3	1094.9	355.2	1041.6	337.0	988.4	318.9	935.1	277.5	813.8	236.1	692.5	194.7	571.2	153.4	450.0
DCY 1900	435.5	1203.6	416.1	1150.4	396.9	1097.1	377.6	1043.9	358.4	990.6	312.3	863.3	266.3	736.0	220.2	608.8	174.1	481.5
DCY 2000	483.6	1277.7	460.8	1217.5	438.0	1157.3	415.3	1097.1	392.4	1036.9	341.6	902.7	290.8	768.4	240.0	634.2	189.2	499.9
DCY 2100	528.2	1333.3	504.3	1273.1	480.5	1212.8	456.7	1152.7	432.8	1092.5	376.9	951.3	320.9	810.1	265.0	668.9	209.0	527.7
DCY 2200	578.3	1398.1	552.4	1335.5	526.5	1273.1	500.7	1210.6	474.8	1148.0	413.5	999.9	352.3	851.8	291.0	703.7	229.7	555.5
DCY 2300	639.1	1462.9	609.7	1395.7	580.4	1328.7	551.1	1261.5	521.8	1194.4	455.1	1041.6	388.3	888.8	321.5	736.0	254.8	583.3
DCY 2400	688.7	1527.6	657.4	1458.2	626.0	1388.8	594.7	1319.3	563.4	1249.9	490.4	1087.9	417.3	925.9	344.3	763.8	271.3	601.8
DCY 2500	752.2	1592.5	717.3	1518.4	682.3	1444.4	647.3	1370.2	612.3	1296.2	533.5	1129.6	454.9	962.9	376.1	796.3	297.4	629.5
DCY 2600	812.2	1657.3	774.8	1580.9	737.3	1504.5	700.0	1428.2	662.5	1351.8	577.4	1178.1	492.3	1004.5	407.2	831.0	322.1	657.3
DCY 2700	871.2	1712.9	832.2	1636.5	793.4	1560.1	754.6	1483.7	715.7	1407.3	622.8	1224.4	529.7	1041.6	436.7	858.7	343.7	675.8
DCY 2800	944.7	1796.2	899.7	1710.5	854.7	1624.9	809.6	1539.2	764.6	1453.6	665.9	1266.1	567.4	1078.6	468.7	891.1	370.1	703.7
DCY 2900	1013.2	1842.5	967.4	1759.2	921.5	1675.8	875.7	1592.5	829.9	1509.2	722.9	1314.7	616.0	1120.3	509.1	925.9	402.2	731.4
DCY 3000	1084.9	1907.3	1034.9	1819.4	984.8	1731.4	934.7	1643.5	884.7	1555.5	770.2	1354.1	655.6	1152.7	541.1	951.3	426.5	750.0

Note : Intermediate performance with similar E/R ratio are available in between grades.

(R: REACTION FORCE (KN) , E: ENERGY ABSORPTION (KJM), TOLERANCE ±10%)

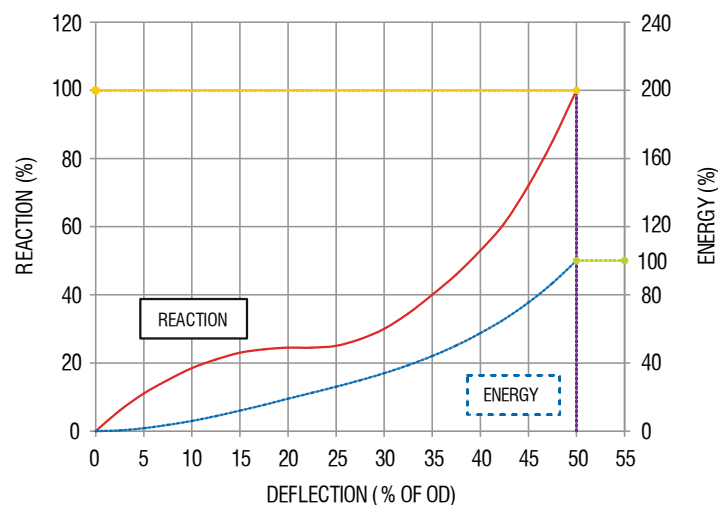

CYLINDRICAL FENDERS - DCY SERIES

CORRECTION FACTORS

ENERGY

Velocity Correction Factor- Energy Absorption	
Berthing Velocity (M/sec)	Correction Factor
0.001	0.978
0.050	0.974
0.100	1.000
0.150	1.000
0.200	1.013
0.250	1.023
0.300	1.026

REACTION

Velocity Correction Factor- Reaction Force	
Berthing Velocity (M/sec)	Correction Factor
0.001	0.901
0.050	0.995
0.100	0.998
0.150	1.000
0.200	1.011
0.250	1.023
0.300	1.027

Temperature Correction Factor- Energy Absorption	
Temperature (Deg C)	Correction Factor
-30	1.32
-20	1.2
-10	1.051
0	1.027
10	1.019
20	1.011
23	1.000
30	0.95
40	0.874
50	0.838

Temperature Correction Factor- Reaction Force	
Temperature (Deg C)	Correction Factor
-30	1.32
-20	1.25
-10	1.17
0	1.072
10	1.055
20	1.011
23	1.0
30	0.95
40	0.883
50	0.88

Angular Correction Factor - Energy Absorption	
Berthing Angle (Degree)	Correction Factor
0	1.000
3	0.982
5	0.953
8	0.947
10	0.923
15	0.913
20	0.910

ARCH FENDERS

IRM Arch Fenders were introduced to improve the performance of cylindrical fenders. Arch Fenders have an enhanced energy/reaction force ratio and are recommended for all types of applications. The “V” shape of these fenders helps to disperse stress evenly.

Arch fenders are manufactured in a single piece with steel insert plates encapsulated in the legs to provide tight fitment to the jetty.

These fenders are robust and have a good shear resistance. They can easily be installed vertically, horizontally or inclined, thereby covering and protecting the jetty more efficiently. Arch Fenders can be manufactured in various lengths depending on the requirement. Arch Fenders can be fitted with a UHMW pad or a frontal frame to reduce friction and hull pressure.

IRM offers various models of Arch Fenders with different performances to fulfil the requirement of multiple clients.

Key Attributes :

- Simple one-piece design
- Excellent shear performance
- Very easy to install
- Maintenance free

Can be modified to be equipped with a frontal frame to suit specific berthing conditions and duties.

Range

Arch Fenders are available in a large range of standard sizes

Applications

- All types of Berths, Jetty Structures
- Barge and Tug berths
- Pontoons



ARCH FENDERS - DA SERIES

DIMENSION TABLE

ALL DIMENSIONS ARE IN MM

MODEL	H	A	B	C	D	F	t	P	Q	X	Y	W	L=1M		L=1.5M		L=2M		L=2.5M		L=3M		WT. Kgs/Mtr
													R	N x Z	R	N x Z	R	N x Z	R	N x Z	R	N x Z	
DA 150H	150	300	240	98	96	22.5	20	95	55	52	26	M22	110	1 x 855	112.5	2 x 675	107.5	3 x 620	110	3 x 785	107.5	4 x 715	40
DA 200H	200	400	320	131	128	30	25	105	75	56	28	M24	120	1 x 860	120	2 x 680	120	3 x 620	122.5	3 x 785	120	4 x 715	65
DA 250H	250	500	410	164	160	37.5	30	125	90	64	32	M27	130	1 x 865	132.5	2 x 680	132.5	3 x 620	127.5	3 x 790	132.5	4 x 715	100
DA 300H	300	600	490	197	192	45	33	140	100	70	35	M30	140	1 x 870	140	2 x 685	137.5	3 x 625	140	3 x 790	145	4 x 715	130
DA 400H	400	800	670	262	256	60	44	165	120	84	42	M36	150	1 x 900	150	2 x 700	147.5	3 x 635	150	3 x 800	150	4 x 725	230
DA 500H	500	1000	840	328	320	75	50	165	130	84	42	M36	160	1 x 930	160	2 x 715	157.5	3 x 645	160	3 x 810	165	4 x 730	355
DA 600H	600	1200	1010	393	384	90	52	180	160	96	48	M42	170	1 x 960	170	2 x 730	167.5	3 x 655	170	3 x 820	170	4 x 740	520
DA 800H	800	1600	1340	524	501	120	70	195	200	108	54	M48	180	1 x 1040	180	2 x 770	180	3 x 680	182.5	3 x 845	180	4 x 760	932
DA 1000H	1000	2000	1680	655	626	150	90	195	240	108	54	M48	200	1 x 1100	200	2 x 800	200	3 x 700	202.5	3 x 865	200	4 x 775	1490

Note : Weight values mentioned are approximate.

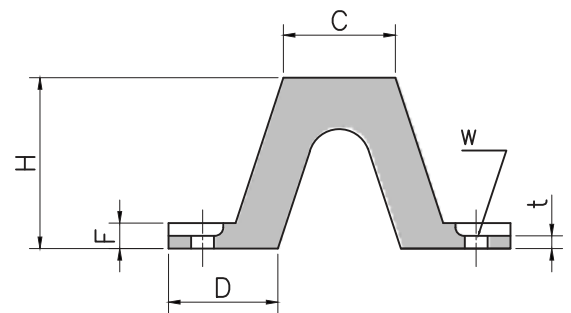
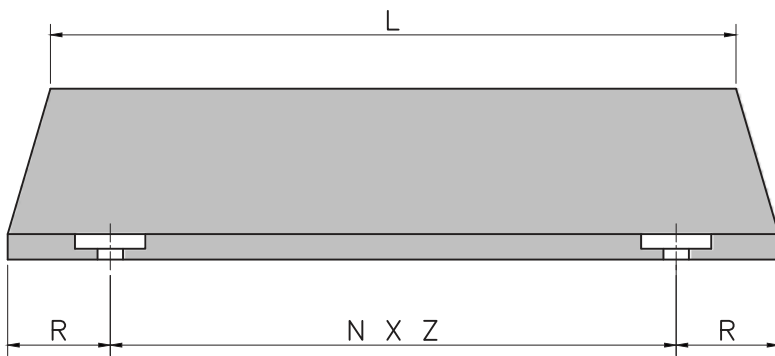
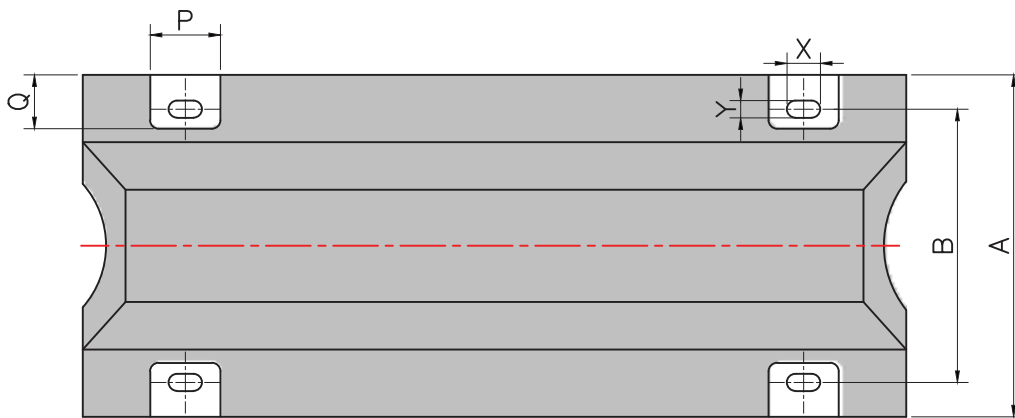

ARCH FENDERS - DA SERIES

PERFORMANCE TABLE (Performance of Unit Length)

Grade Deflection Model	R1		R1.1		R2		R2.1		R3		R3.1		R4															
	45%	50%	45%	50%	45%	50%	45%	50%	45%	50%	45%	50%	45%	50%														
	E	R	E	R	E	R	E	R	E	R	E	R	E	R	E	R												
DA150H	6.8	125.5	8.8	168.6	6.1	116.7	8.1	156.9	5.3	107.8	7.3	145.1	4.9	94.1	6.2	126.5	4.4	80.4	5.1	107.8	3.7	67.6	4.3	91.2	2.9	53.9	3.4	73.5
DA200H	14.7	169.6	16.6	223.5	13.7	159.8	15.6	208.8	12.7	149.0	14.7	194.1	10.7	129.4	12.7	171.6	8.8	109.8	10.7	148.0	7.3	91.2	8.8	123.5	5.8	72.5	6.8	98.0
DA250H	18.6	208.8	21.5	234.3	17.6	195.1	20.5	239.2	16.6	180.4	19.6	243.2	14.7	158.8	17.1	213.7	12.7	136.3	14.7	184.3	10.7	113.7	12.7	153.9	8.8	91.2	10.7	122.5
DA300H	26.4	250.0	31.3	337.3	25.5	233.4	29.9	316.7	24.5	215.7	28.4	295.1	21.5	189.2	25.0	258.9	18.6	161.8	21.5	221.6	15.6	137.2	18.1	186.3	12.7	111.8	14.7	151.0
DA400H	43.1	337.3	53.9	456.0	42.6	314.7	50.5	424.6	42.1	291.2	47.0	393.2	36.7	254.9	42.6	344.2	31.3	218.6	38.2	295.1	26.9	184.3	32.3	248.1	22.5	149.0	26.4	201.0
DA500H	69.6	418.7	85.3	567.8	68.6	392.2	80.4	530.5	67.6	364.8	75.5	492.2	58.3	318.7	66.6	429.5	49.0	272.6	57.8	366.7	40.2	226.5	47.5	306.9	31.3	180.4	37.2	247.1
DA600H	101.0	502.1	117.6	679.6	96.1	469.7	111.8	636.4	90.2	436.4	104.9	593.3	80.4	383.9	93.1	520.7	69.6	331.4	80.4	448.1	57.8	275.5	66.6	372.6	46.0	218.6	52.9	296.1
DA800H	183.3	671.7	209.8	907.1	171.6	627.6	200.0	849.2	159.8	583.5	189.2	790.4	140.2	513.8	165.7	693.3	120.6	443.2	141.2	595.2	101.0	367.7	117.6	497.2	81.4	291.2	94.1	398.1
DA1000H	280.4	841.4	369.7	1137.5	266.7	786.4	331.4	1064.0	252.0	731.5	292.2	990.4	219.6	641.3	259.8	866.9	187.3	551.1	226.5	742.3	161.3	458.9	192.7	618.8	135.3	365.7	158.8	495.2

Note : Intermediate performance with similar E/R ratio are available in between grades.

(R: REACTION FORCE (KN) , E: ENERGY ABSORPTION (KNM), TOLERANCE ±10%)

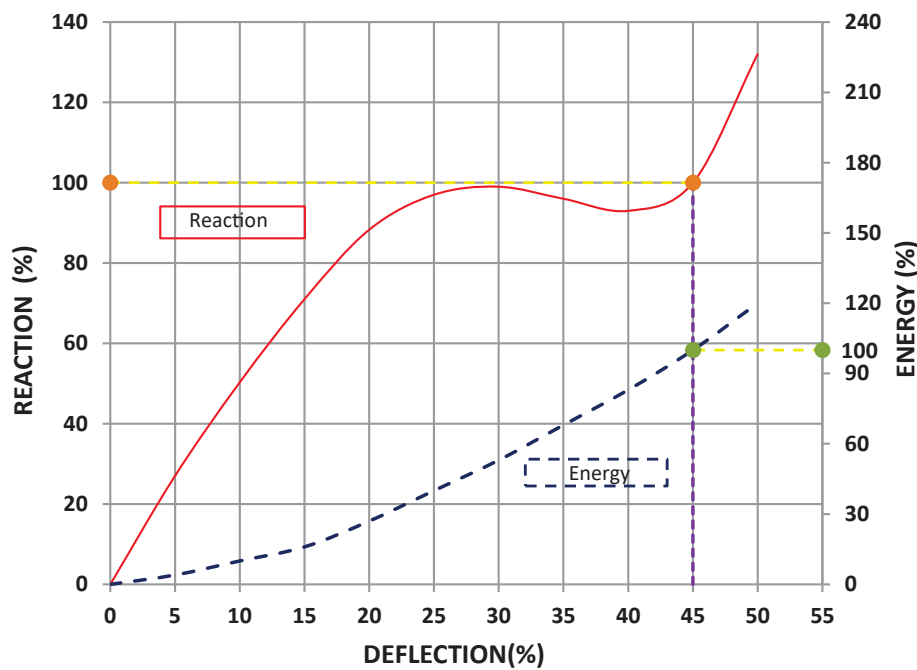

DYNA ARCH FENDERS - DYA SERIES

DIMENSION TABLE

ALL DIMENSIONS ARE IN MM

MODEL	H	A	B	C	D	F	t	P	Q	X	Y	W	L=1M		L=1.5M		L=2M		L=2.5M		L=3M		WT. Kgs/Mtr
													R	N x Z	R	N x Z	R	N x Z	R	N x Z	R	N x Z	
DYA 250H	250	500	410	164	160	27.5	24	125	90	64	32	M27	130	1 x 865	132.5	2 x 680	132.5	3 x 620	127.5	3 x 790	132.5	4 x 715	85
DYA 300H	300	600	490	225	195	33	27	140	100	70	35	M30	140	1 x 870	140	2 x 685	137.5	3 x 625	140	3 x 790	145	4 x 715	120
DYA 400H	400	800	670	300	260	40	30	165	120	84	42	M36	150	1 x 900	150	2 x 700	147.5	3 x 635	150	3 x 800	150	4 x 725	208
DYA 500H	500	1000	840	375	325	45	33	165	130	84	42	M36	160	1 x 930	160	2 x 715	157.5	3 x 645	160	3 x 810	165	4 x 730	325
DYA 600H	600	1200	1010	450	390	54	36	180	160	96	48	M42	170	1 x 960	170	2 x 730	167.5	3 x 655	170	3 x 820	170	4 x 740	480
DYA 800H	800	1600	1340	600	520	72	48	195	200	108	54	M48	180	1 x 1040	180	2 x 770	180	3 x 680	182.5	3 x 845	180	4 x 760	875
DYA 1000H	1000	2000	1680	750	650	90	52	195	240	108	54	M48	200	1 x 1100	200	2 x 800	200	3 x 700	202.5	3 x 865	200	4 x 775	1395

Note : Weight values mentioned are approximate.

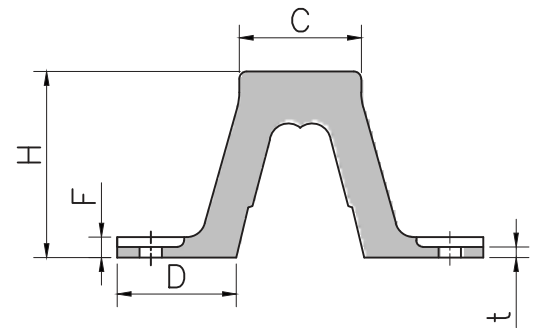
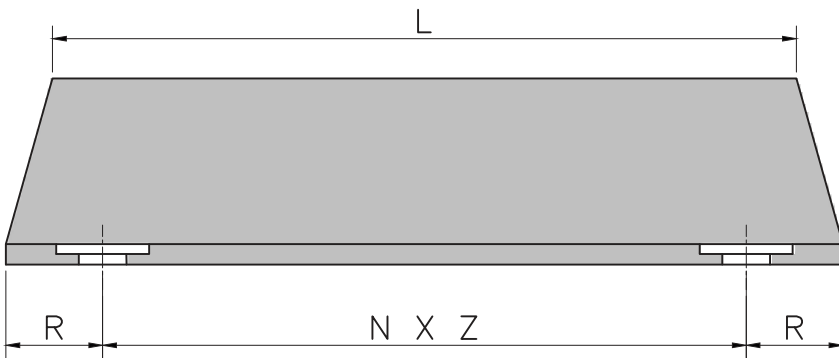
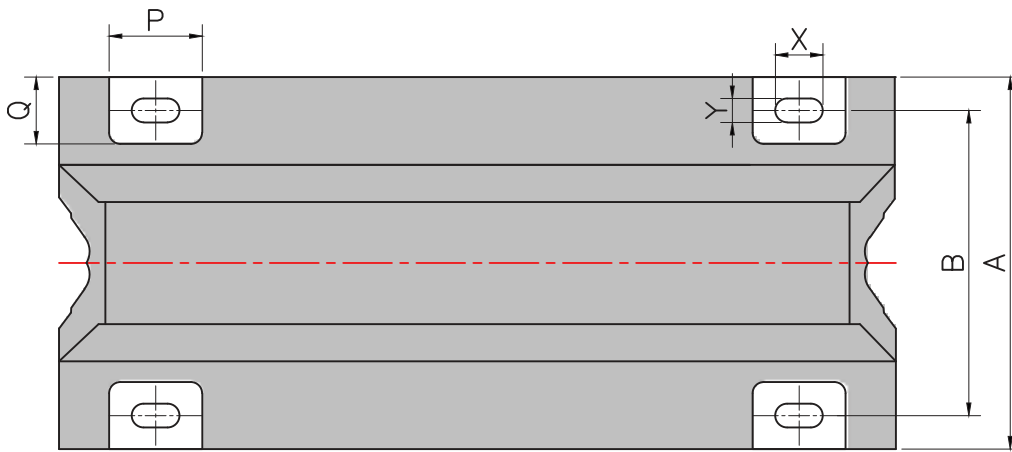

DYNA ARCH FENDERS - DYA SERIES

PERFORMANCE TABLE (Performance of Unit Length)

Grade Deflection Model	R1				R2				R3				R4			
	52%		55%		52%		55%		52%		55%		52%		55%	
	E	R	E	R	E	R	E	R	E	R	E	R	E	R	E	R
DYA 250H	27.4	264.7	29.4	367.7	21.5	203.9	22.5	282.4	17.6	168.6	18.6	234.3	15.6	145.1	16.6	201.0
DYA 300H	40.2	317.7	43.1	441.3	30.4	244.1	32.3	339.3	25.5	202.0	27.4	280.4	21.5	173.5	23.5	241.2
DYA 400H	71.5	423.6	76.4	588.4	54.9	325.5	58.8	452.0	45.1	269.6	48.0	374.6	39.2	231.4	42.1	321.6
DYA 500H	110.8	529.5	118.6	735.5	85.3	406.9	91.2	564.8	70.6	337.3	75.5	468.7	60.8	289.3	64.7	402.0
DYA 600H	159.8	634.4	171.6	881.6	123.5	488.3	132.3	678.6	101.9	404.0	108.8	560.9	87.2	347.1	93.1	482.4
DYA 800H	284.3	847.2	304.9	1176.8	218.6	651.1	234.3	904.1	181.4	539.3	194.1	749.2	155.9	462.8	166.7	643.3
DYA 1000H	445.2	1059.1	476.6	1471.0	342.2	813.9	366.7	1130.7	283.4	674.7	304.0	937.5	243.2	578.5	260.8	804.1

Note : Intermediate performance with similar E/R ratio are available in between grades.

(R: REACTION FORCE (KN) , E: ENERGY ABSORPTION (KNM), TOLERANCE ±10%)

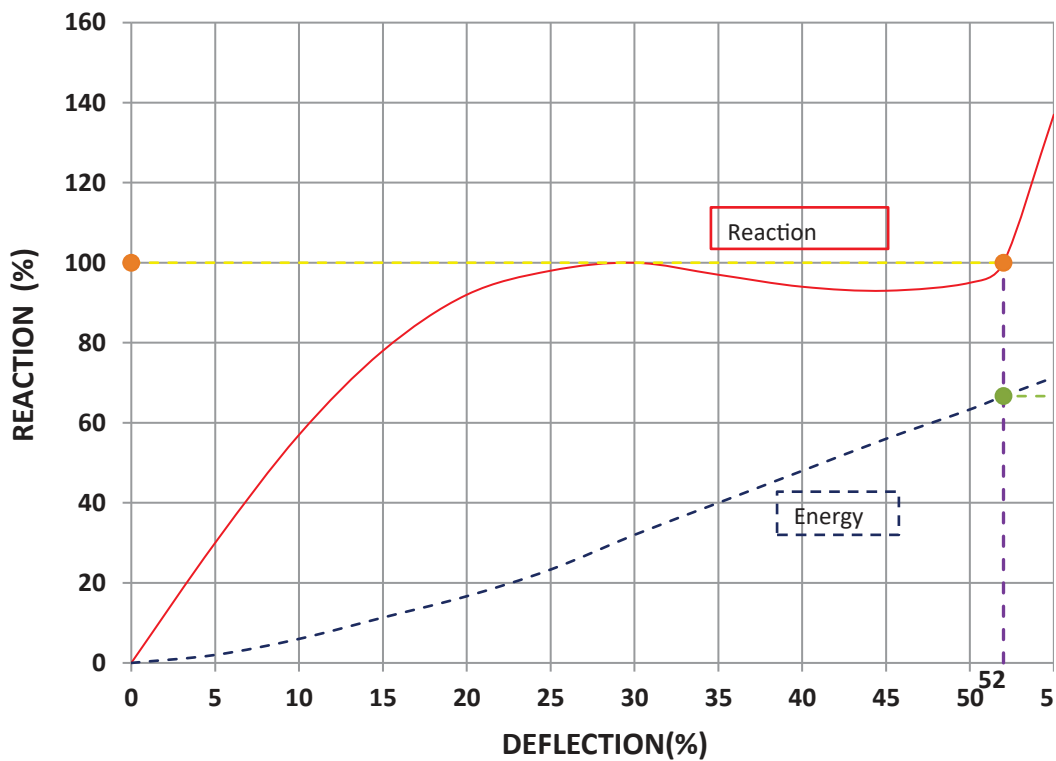

ARCH FENDERS - DAV SERIES

DIMENSION TABLE

ALL DIMENSIONS ARE IN MM

MODEL	H	A	B	C	D	F	X	Y	W	L=1M		L=1.5M		L=2M		L=2.5M		L=3M		WT Kgs/Mtr
										R	N x Z	R	N x Z	R	N x Z	R	N x Z	R	N x Z	
DAV 150H	150	326	240	98	108	16	40	20	M16	50	2 x 500	50	3 x 500	50	4 x 500	50	5 x 500	50	6 x 500	30
DAV 200H	200	422	320	130	142	18	50	25	M20	50	2 x 500	50	3 x 500	50	4 x 500	50	5 x 500	50	6 x 500	48
DAV 250H	250	500	400	163	164	20	56	28	M24	62.5	2 x 500	62.5	3 x 500	62.5	4 x 500	62.5	5 x 500	62.5	6 x 500	70
DAV 300H	300	595	480	195	194	24	56	28	M24	75	2 x 500	75	3 x 500	75	4 x 500	75	5 x 500	75	6 x 500	108
DAV 400H	400	808	640	260	266	26	70	35	M30	100	2 x 500	100	3 x 500	100	4 x 500	100	5 x 500	100	6 x 500	186
DAV 500H	500	981	800	325	318	26	84	42	M36	125	2 x 500	125	3 x 500	125	4 x 500	125	5 x 500	125	6 x 500	280
DAV 600H	600	1160	960	390	373	28	96	48	M42	150	2 x 500	150	3 x 500	150	4 x 500	150	5 x 500	150	6 x 500	412
DAV 800H	800	1550	1300	520	499	41	108	54	M48	200	2 x 500	200	3 x 500	200	4 x 500	200	5 x 500	200	6 x 500	770
DAV 1000H	1000	1850	1550	650	580	52	108	54	M48	250	2 x 500	250	3 x 500	250	4 x 500	250	5 x 500	250	6 x 500	1300

Note : Weight values mentioned are approximate.

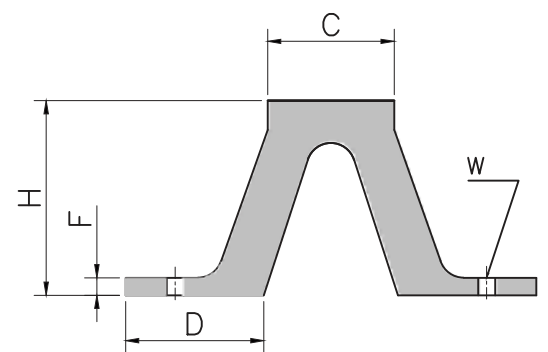
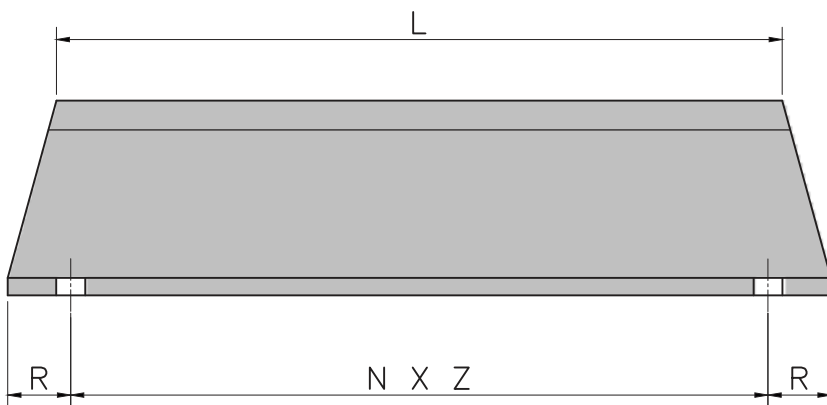
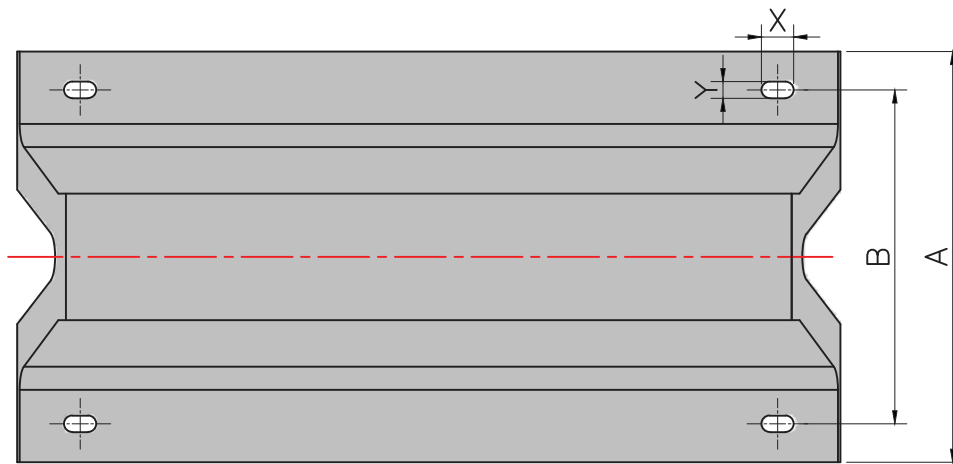

ARCH FENDERS - DAV SERIES

PERFORMANCE TABLE (Performance of Unit Length)

Grade	R1		R1.1		R2		R2.1		R3		R3.1	
MODEL	E	R	E	R	E	R	E	R	E	R	E	R
DAV 150H	7.2	124.5	6.3	109.8	5.4	94.1	4.9	83.3	4.2	72.5	3.8	66.1
DAV 200H	12.8	165.7	11.3	146.1	9.8	125.5	8.6	111.8	7.4	97.0	6.6	89.2
DAV 250H	20.1	206.9	17.7	182.4	15.3	156.9	13.5	139.2	11.6	120.6	10.4	109.8
DAV 300H	28.9	248.1	25.5	218.6	22.0	188.2	19.4	166.7	16.7	145.1	14.9	132.3
DAV 400H	51.4	332.4	45.4	292.2	39.2	251.0	34.6	222.6	29.9	193.1	26.7	176.5
DAV 500H	80.4	413.8	70.8	364.8	61.1	314.7	53.9	278.5	46.6	242.2	41.7	219.6
DAV 600H	113.7	497.2	101.0	437.3	88.1	377.5	77.4	333.9	67.2	290.2	59.2	262.8
DAV 800H	205.9	661.9	181.4	582.5	156.9	503.0	138.2	445.2	119.6	386.3	106.8	349.1
DAV 1000H	321.6	827.6	283.4	728.6	245.1	628.6	216.7	556.0	187.3	483.4	167.6	438.3

Note : Intermediate performance with similar E/R ratio are available in between grades.

(R: REACTION FORCE (KN), E: ENERGY ABSORPTION (KNM), TOLERANCE ±10%)

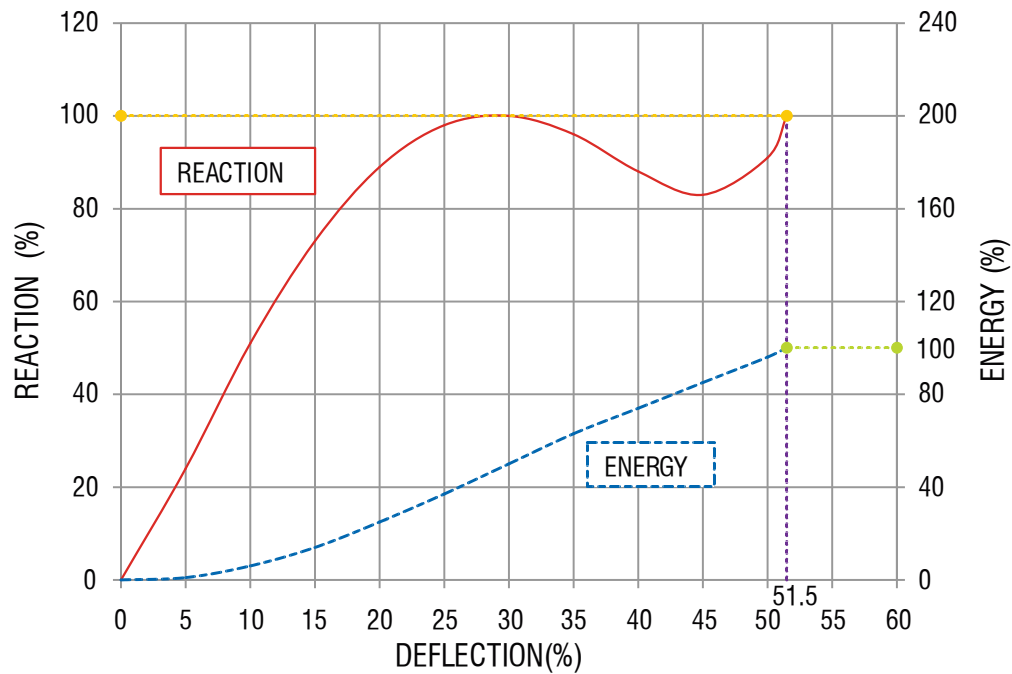

ARCH FENDERS - DAVP SERIES

DIMENSION TABLE

ALL DIMENSIONS ARE IN MM

MODEL	H	A	B	C	D	T	F	X	Y	W	R	L=1M		L=1.5M		L=2M		L=2.5M		L=3M		Total Weight kgs/Mtr
												N x Z	R	N x Z	R	N x Z	R	N x Z	R	N x Z		
DAVP 150H	150	326	240	98	108	30	16	40	20	M16	50	2 x 500	50	3 x 500	50	4 x 500	50	5 x 500	50	6 x 500	35	
DAVP 200H	200	422	320	130	142	30	18	50	25	M20	50	2 x 500	50	3 x 500	50	4 x 500	50	5 x 500	50	6 x 500	56	
DAVP 250H	250	500	400	163	164	30	20	56	28	M24	62.5	2 x 500	62.5	3 x 500	62.5	4 x 500	62.5	5 x 500	62.5	6 x 500	80	
DAVP 300H	300	595	480	195	194	30	24	56	28	M24	75	2 x 500	75	3 x 500	75	4 x 500	75	5 x 500	75	6 x 500	120	
DAVP 400H	400	808	640	260	266	40	26	70	35	M30	100	2 x 500	100	3 x 500	100	4 x 500	100	5 x 500	100	6 x 500	206	
DAVP 500H	500	981	800	325	318	50	26	84	42	M36	125	2 x 500	125	3 x 500	125	4 x 500	125	5 x 500	125	6 x 500	310	
DAVP 600H	600	1160	960	390	373	50	28	96	48	M42	150	2 x 500	150	3 x 500	150	4 x 500	150	5 x 500	150	6 x 500	457	
DAVP 800H	800	1550	1300	520	499	60	41	108	54	M48	200	2 x 500	200	3 x 500	200	4 x 500	200	5 x 500	200	6 x 500	840	
DAVP 1000H	1000	1850	1550	650	580	60	52	108	54	M48	250	2 x 500	250	3 x 500	250	4 x 500	250	5 x 500	250	6 x 500	1405	

Note : Weight values mentioned are approximate.

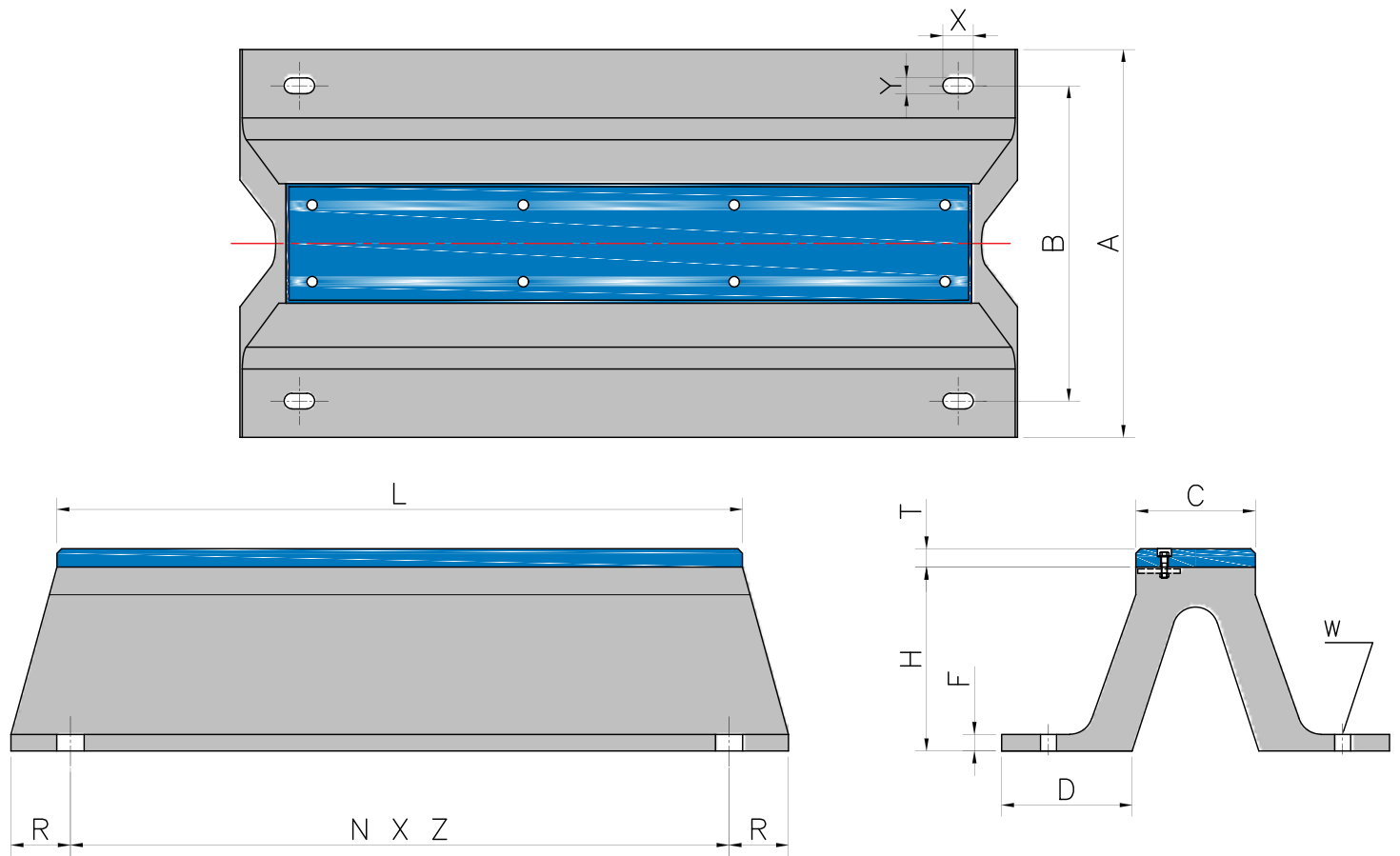

ARCH FENDERS - DAVP SERIES

PERFORMANCE TABLE (Performance of Unit Length)

Grade	R1		R1.1		R2		R2.1		R3		R3.1	
MODEL	E	R	E	R	E	R	E	R	E	R	E	R
DAVP 150H	9.3	147.1	8.2	130.4	7.1	112.7	6.3	100.0	5.4	87.2	4.7	78.4
DAVP 200H	16.4	196.1	14.6	173.5	12.6	151.0	11.1	133.3	9.7	115.7	8.2	102.9
DAVP 250H	25.7	245.1	22.8	216.7	19.8	188.2	17.5	166.7	15.3	145.1	13.8	130.4
DAVP 300H	37.0	294.2	32.8	260.8	28.5	226.5	25.3	201.0	21.9	174.5	19.7	155.9
DAVP 400H	65.9	392.2	58.3	347.1	50.7	302.0	44.9	267.7	39.0	232.4	35.0	208.8
DAVP 500H	102.9	490.3	91.1	435.4	79.2	380.5	70.1	335.3	60.9	290.2	54.5	254.9
DAVP 600H	148.0	588.4	131.4	520.7	113.7	453.0	101.0	400.6	87.5	348.1	78.4	296.1
DAVP 800H	263.8	784.5	233.4	694.3	203.0	603.1	179.4	533.4	155.9	463.8	139.2	414.8
DAVP 1000H	411.8	980.6	266.7	867.8	316.7	754.1	280.4	667.8	244.1	580.5	219.6	520.7

Note : Intermediate performance with similar E/R ratio are available in between grades.

(R: REACTION FORCE (KN) , E: ENERGY ABSORPTION (KNM), TOLERANCE ±10%)

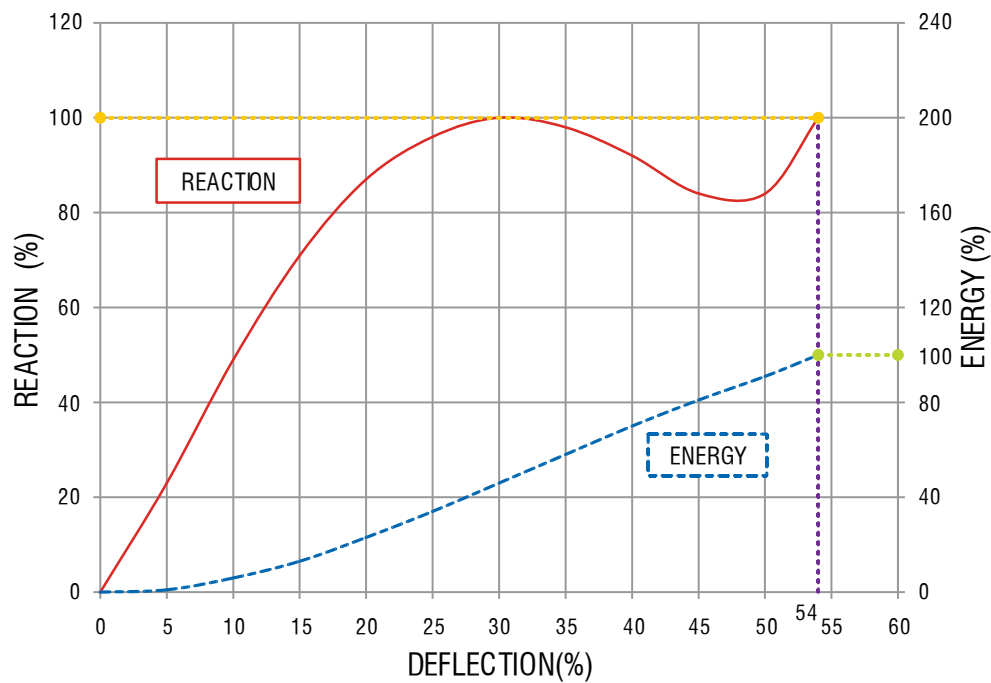

FLAT TOP ARCH FENDERS - DFTA SERIES

DIMENSION TABLE

ALL DIMENSIONS ARE IN MM

MODEL	H	A	B	C	D	F	W	t	P	Q	X	Y	L=1M		L=1.5M		L=2M		L=2.5M		L=3M		WT. Kgs/Mtr
													R	N x Z	R	N x Z	R	N x Z	R	N x Z	R	N x Z	
DFTA 250H	250	625	530	280	202.5	30	M27	26	125	90	64	32	120	1 X 830	120	2 X 670	120	3 x 650	120	3 x 800	115	4 x 720	100
DFTA 300H	300	750	640	340	245	36	M30	30	140	100	70	35	130	1 X 840	125	2 X 670	130	3 x 655	125	3 x 820	135	4 x 740	152
DFTA 400H	400	1000	850	450	325	40	M36	33	165	130	84	42	140	1 X 850	140	2 X 670	140	3 x 660	140	3 x 840	135	4 x 760	248
DFTA 500H	500	1200	1040	560	380	45	M36	36	165	130	84	42	150	1 X 840	150	2 X 675	150	3 x 665	150	3 x 860	150	4 x 780	390
DFTA 600H	600	1400	1230	675	437.5	50	M42	40	180	160	96	48	170	1 X 840	170	2 X 670	170	3 x 670	170	3 x 880	165	4 x 800	553
DFTA 800H	800	1800	1600	900	550	75	M48	60	220	180	108	54	200	1 X 840	200	2 X 670	200	3 x 680	200	3 x 900	195	4 x 820	946
DFTA 1000H	1000	2200	2000	1125	662.5	100	M48	75	220	180	108	54	230	1 X 840	230	2 X 670	230	3 x 700	230	3 x 920	225	4 x 840	1428

Note : Weight values mentioned are approximate.

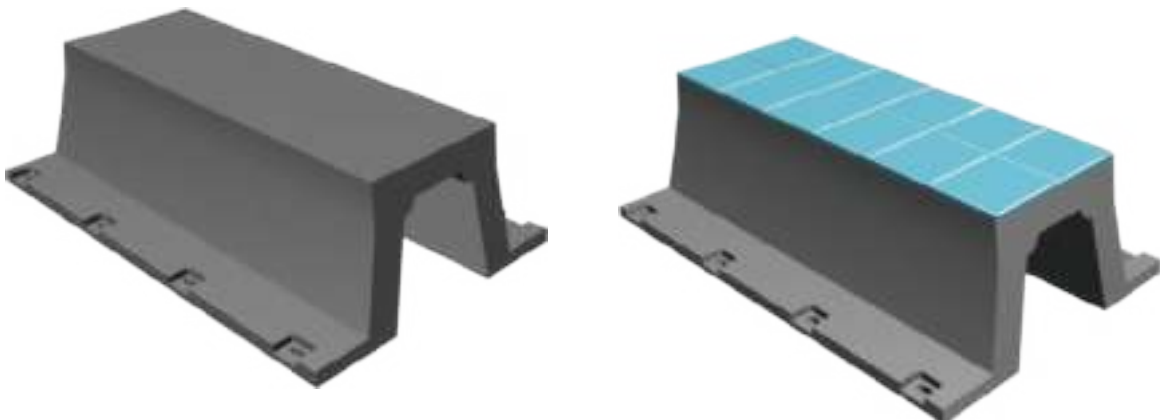
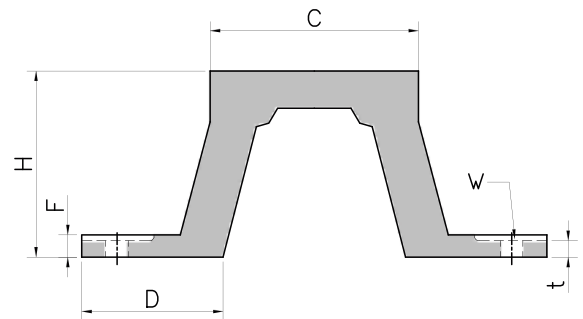
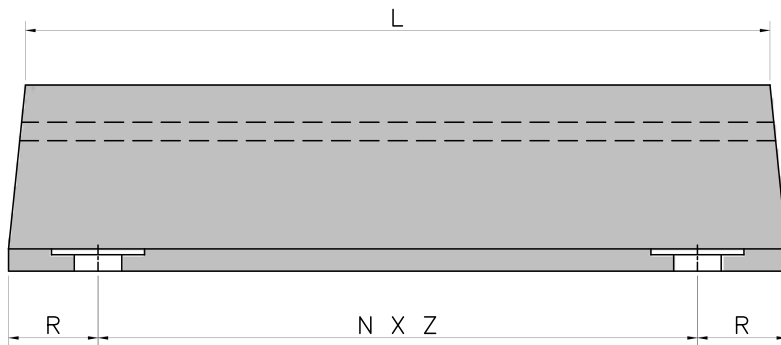
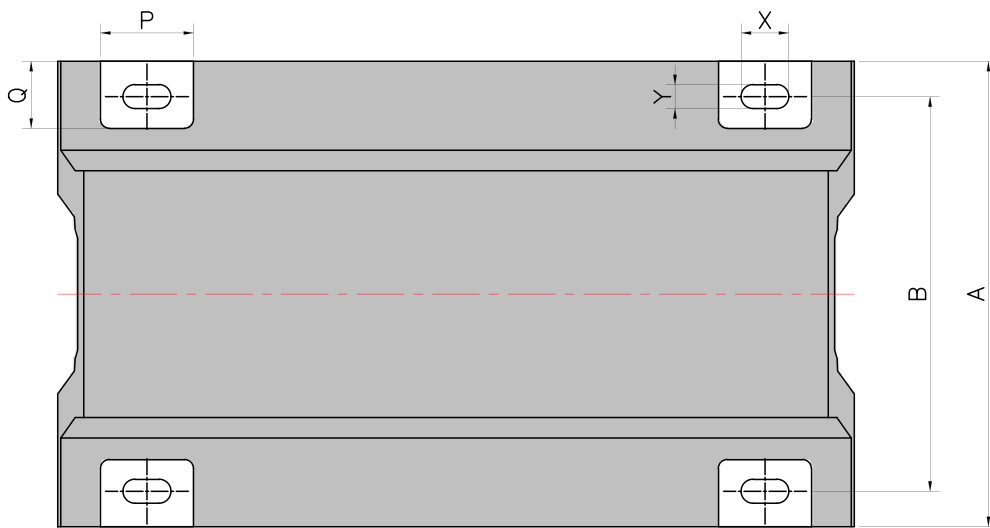

FLAT TOP ARCH FENDERS - DFTA SERIES

PERFORMANCE TABLE (Performance of Unit Length)

Grade	R1		R2		R3		R4	
Deflection	52.5%		52.5%		52.5%		52.5%	
Model	E	R	E	R	E	R	E	R
DFTA 250H	27.9	261.6	21.5	204.8	17.9	168.5	14.1	132.3
DFTA 300H	39.6	315.5	30.7	243.0	27.4	201.8	25.4	163.6
DFTA 400H	70.8	423.3	54.4	326.3	45.2	268.5	36.5	218.6
DFTA 500H	112.7	527.2	85.4	405.7	70.9	340.0	57.0	269.5
DFTA 600H	158.7	632.1	121.5	487.0	101.9	407.7	81.6	324.4
DFTA 800H	285.2	846.3	215.6	649.7	182.2	541.0	143.0	431.2
DFTA 1000H	442.9	1059.1	340.0	811.4	284.2	676.2	228.3	541.9

Note : Intermediate performance with similar E/R ratio are available in between grades.

(R: REACTION FORCE (KN) , E: ENERGY ABSORPTION (KNM), TOLERANCE ±10%)

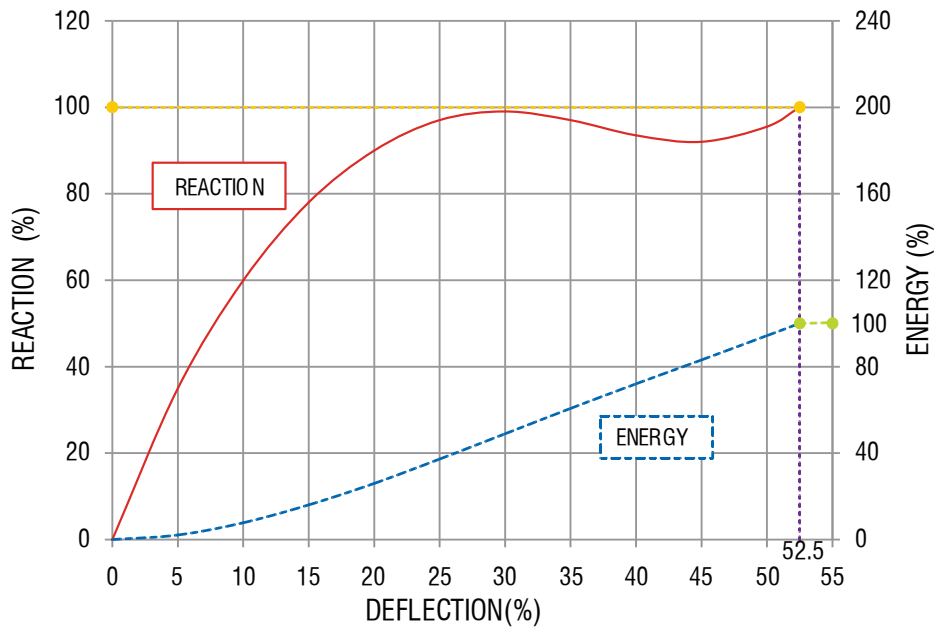

ARCH FENDERS - DAFB SERIES

IRM Arch fender DAFB series are a modified version of Arch fenders. A continuous base is provided in the DAFB series for better mounting on steel structures. The base of the fenders consists of a steel plate encapsulated in Rubber to offer firm support. These fenders can be used for all the applications like Arch fenders but are generally preferred for offshore applications. Performance characteristics of DAFB fenders are quite similar to Arch Fenders.

DIMENSION TABLE

ALL DIMENSIONS ARE IN MM

MODEL	H	A	B	C	D	F	G	W	L=1M		L=1.5M		L=2M		L=2.5M		L=3M	
									R	NXS	R	NXS	R	NXS	R	NXS	R	NXS
DAFB 150H	150	320	260	95	20	190	50	M20	250	1 X 500	250	2 X 500	250	3 X 500	250	4 X 500	250	5 X 500
DAFB 200H	200	380	310	125	30	250	55	M24	250	1 X 500	250	2 X 500	250	3 X 500	250	4 X 500	250	5 X 500
DAFB 250H	250	500	400	155	40	315	60	M24	250	1 X 500	250	2 X 500	250	3 X 500	250	4 X 500	250	5 X 500
DAFB 300H	300	645	530	188	60	375	85	M30	250	1 X 500	250	2 X 500	250	3 X 500	250	4 X 500	250	5 X 500
DAFB 400H	400	840	710	250	60	500	135	M36	250	1 X 500	250	2 X 500	250	3 X 500	250	4 X 500	250	5 X 500
DAFB 500H	500	1000	860	315	60	625	190	M36	250	1 X 500	250	2 X 500	250	3 X 500	250	4 X 500	250	5 X 500
DAFB 600H	600	1210	1050	375	60	750	240	M42	250	1 X 500	250	2 X 500	250	3 X 500	250	4 X 500	250	5 X 500
DAFB 800H	800	1550	1350	500	60	1000	335	M48	250	1 X 500	250	2 X 500	250	3 X 500	250	4 X 500	250	5 X 500
DAFB 1000H	1000	1800	1600	625	60	1250	450	M48	250	1 X 500	250	2 X 500	250	3 X 500	250	4 X 500	250	5 X 500
DAFB 1300H	1300	2250	2330	815	60	1650	630	M56	250	1 X 500	250	2 X 500	250	3 X 500	250	4 X 500	250	5 X 500

TYPE 1

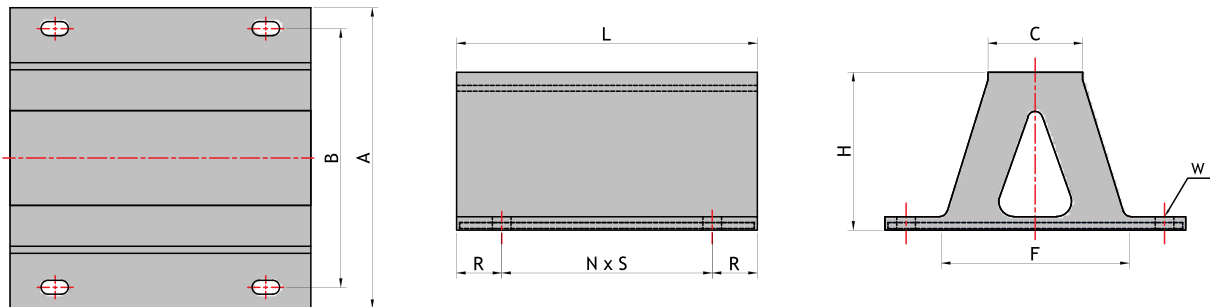

TYPE 2

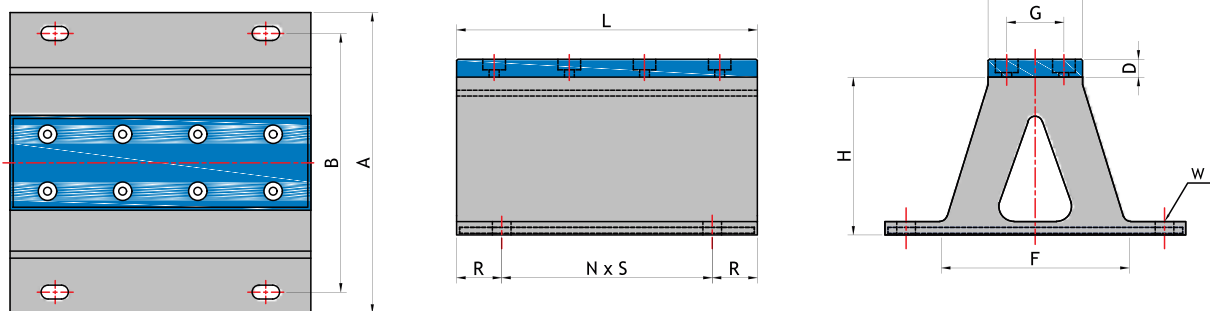

TYPE 3

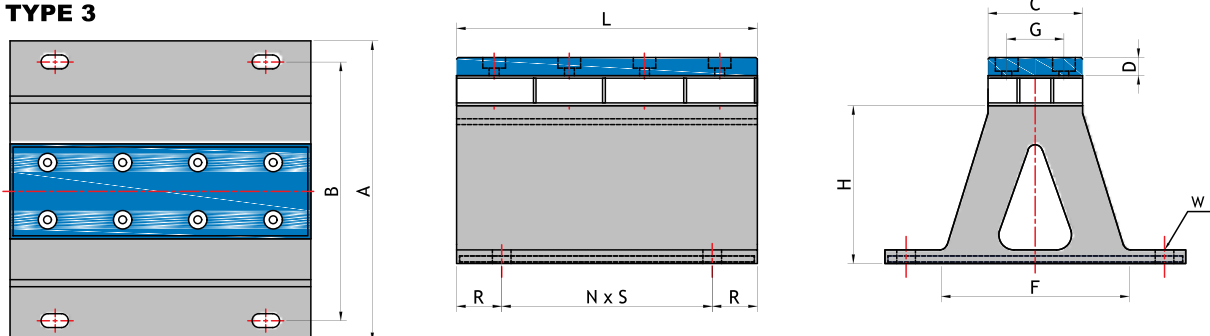

ARCH FENDERS

CORRECTION FACTORS

ENERGY

Velocity Correction Factor-Energy Absorption	
Berthing Velocity (M/sec)	Correction Factor-Energy Absorption
0.001	0.948
0.050	1.012
0.100	1.015
0.150	1.000
0.200	0.996
0.250	0.987
0.300	0.978

REACTION

Velocity Correction Factor-Reaction Force	
Berthing Velocity (M/sec)	Correction Factor-Reaction Force
0.001	1.029
0.050	1.058
0.100	1.008
0.150	1.000
0.200	0.970
0.250	0.968
0.300	0.950

Temperature Correction Factor-Energy Absorption	
Temperature (Deg C)	Reaction Correc Factor
-30	1.099
-20	1.077
-10	1.081
0	1.063
10	1.046
20	0.973
23	1.000
30	0.946
40	0.899
50	0.838

Temperature Correction Factor-Reaction Force	
Temperature (Deg C)	Reaction Correc Factor
-30	1.096
-20	1.065
-10	1.05
0	1.036
10	1.033
20	1.02
23	1.000
30	0.986
40	0.975
50	0.946

Angular Correction Factor - Energy Absorption	
Berthing Angle(Degree)	Energy Absorption Correction Factor
0	1.000
3	0.970
5	0.948
8	0.916
10	0.896
15	0.843
20	0.731

W FENDERS - DW SERIES

IRM DW series “W” Type Fender is a further development of the Arch and Flat Top Arch Fender. “W” Fenders have more deflection and better energy/reaction ratio than the Arch Fenders. As the fender has a broader face, the hull pressure is relatively low compared to both Arch and Flat Top Arch Fenders.

These types of fenders can be easily installed and are maintenance-free. A wide range is available for different vessels.

Various types of vessels can berth on these fenders due to their better resilience and deflection. The “IRM DW” Type Fenders can be fitted easily to any type of berthing structure. These fenders can also be supplemented with anti-friction and anti-sparking UHMW or HDPE fascia pads to increase their service life.

Key Attributes :

- Simple one-piece design
- Excellent shear performance
- Very easy to install
- Maintenance free

Range

DW series “W” Type fenders are available in a wide range from 250mm height to 1000mm height in different lengths as per specific requirements.

Applications

- Barge and Tug berths
- All types of Berths, Jetty Structures



W FENDERS - DW SERIES

DIMENSION TABLE

ALL DIMENSIONS ARE IN MM

MODEL	H	A	B	C	D	F	W	t	P	Q	X	Y	L=1M		L=1.5M		L=2M		L=2.5M		L=3M		L=3.5M		WT. Kgs/Mtr
													R	N x Z	R	N x Z	R	N x Z	R	N x Z	R	N x Z	R	N x Z	
DW 250H	250	625	535	330	170	28	M27	24	125	90	64	32	130	1 x 865	132.5	2 x 680	132.5	3 x 620	127.5	3 x 790	132.5	4 x 715	130	5 x 673	100
DW 300H	300	750	640	396	204	33	M30	27	140	100	70	35	140	1 x 870	140	2 x 685	137.5	3 x 625	140	3 x 790	145	4 x 715	140	5 x 674	140
DW 400H	400	1000	870	528	272	44	M36	34	165	120	84	42	150	1 x 900	150	2 x 700	147.5	3 x 635	150	3 x 800	150	4 x 725	150	5 x 680	242
DW 500H	500	1250	1090	660	340	55	M42	42	180	140	96	48	160	1 x 930	160	2 x 715	157.5	3 x 645	160	3 x 810	165	4 x 730	160	5 x 686	378
DW 600H	600	1500	1310	776	408	66	M48	50	195	160	108	54	170	1 x 960	170	2 x 730	167.5	3 x 655	170	3 x 820	170	4 x 740	170	5 x 692	550
DW 800H	800	2000	1740	1035	544	88	M56	60	210	210	124	62	180	1x1040	180	2 x 770	180	3 x 680	182.5	3 x 845	180	4 x 760	200	5 x 700	985
DW 1000H	1000	2480	2180	1265	670	110	M56	80	220	240	124	62	200	1x1100	200	2 x 800	200	3 x 700	210	3 x 860	220	4 x 765	250	5 x 700	1580

Note : Weight values mentioned are approximate.

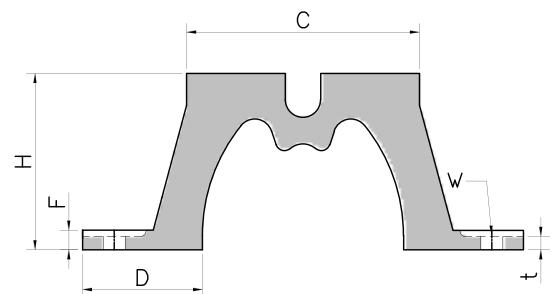
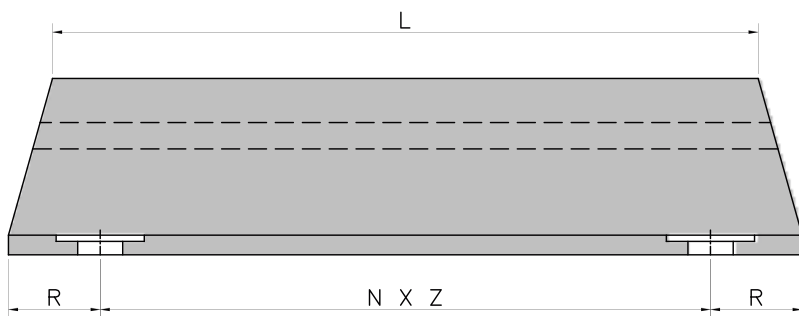
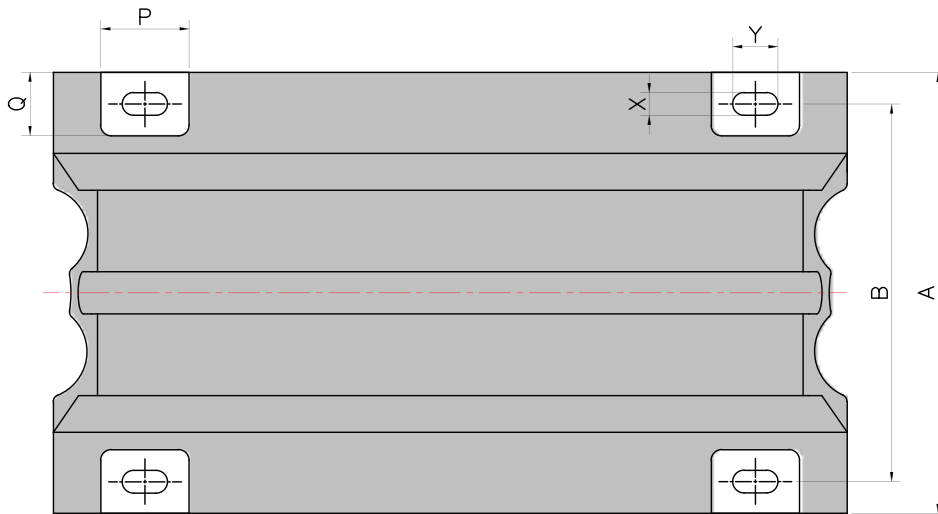

W FENDERS - DW SERIES

PERFORMANCE TABLE (Performance of Unit Length)

GRADE	R1				R2				R3				R4			
	50%		55%		50%		55%		50%		55%		50%		55%	
DEFLECTION	E	R	E	R	E	R	E	R	E	R	E	R	E	R	E	R
MODEL	E	R	E	R	E	R	E	R	E	R	E	R	E	R	E	R
DW 250H	30.8	278.5	34.3	390.3	23.0	210.8	25.0	301.0	18.1	178.4	21.5	241.2	17.1	149.0	18.1	208.8
DW 300H	41.6	333.4	48.0	475.6	31.8	253.0	35.3	359.9	25.9	210.8	30.4	292.2	22.0	178.4	25.9	247.1
DW 400H	74.5	443.2	85.8	622.7	55.4	336.3	62.2	480.5	44.1	278.5	51.9	394.2	39.2	239.2	46.5	335.3
DW 500H	116.7	556.0	134.3	787.4	85.8	423.6	96.1	598.2	71.1	355.0	81.8	488.3	61.2	302.0	68.6	411.8
DW 600H	167.6	666.8	188.2	939.4	120.6	512.8	140.2	727.6	102.9	420.7	117.6	587.4	85.8	360.8	96.1	497.2
DW 800H	296.1	894.3	336.3	1255.2	214.7	687.4	248.1	966.9	181.4	563.8	207.9	782.5	152.0	485.4	175.5	668.8
DW 1000H	462.8	1127.7	524.6	1569.0	335.3	854.1	366.7	1206.2	279.4	707.0	323.6	975.7	238.3	609.9	269.6	828.6

Note : Intermediate performance with similar E/R ratio are available in between grades.

(R: REACTION FORCE (KN) , E: ENERGY ABSORPTION (KNM), TOLERANCE ±10%)

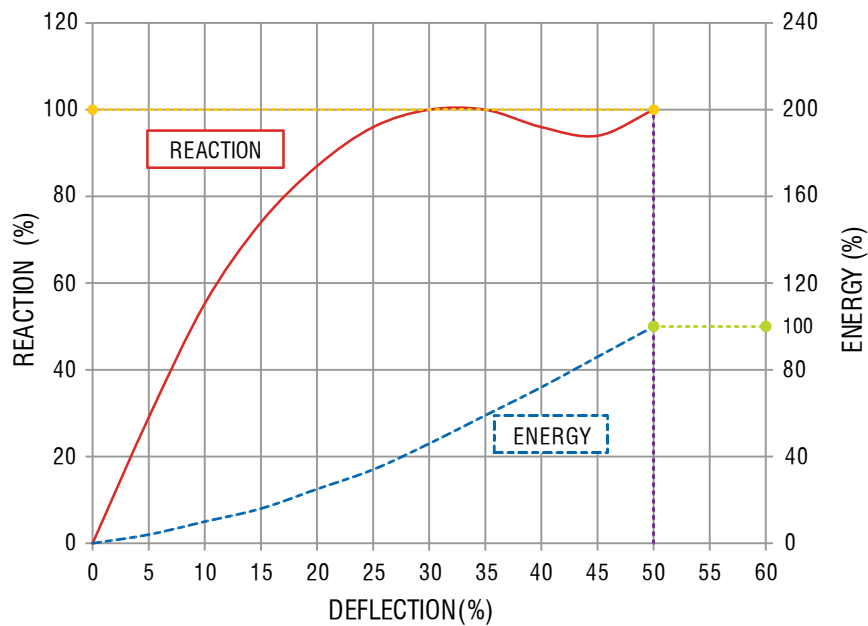

DDA FENDERS - A, B & C SERIES

PERFORMANCE TABLE (Performance of Unit Length)

GRADE	R1						R2					
	45%		50%		55%		45%		50%		55%	
DEFLECTION	E (KNM)	R (KN)	E (KNM)	R (KN)	E (KNM)	R (KN)	E (KNM)	R (KN)	E (KNM)	R (KN)	E (KNM)	R (KN)
DDA 150H	6.57	121.80	7.35	127.49	8.43	128.86	5.49	101.50	6.18	102.97	7.35	107.38
DDA 200H	11.77	162.40	13.14	167.69	15.00	171.81	9.81	135.33	10.98	136.80	12.55	143.18
DDA 250H	18.34	203.00	20.59	206.43	23.54	214.77	15.30	169.16	17.16	175.05	19.61	179.27
DDA 300H	26.48	243.60	29.62	247.62	33.83	257.72	22.06	203.00	24.71	205.94	28.24	214.77
DDA 400H	47.07	324.80	52.66	334.80	60.21	343.63	39.23	270.66	43.93	276.55	50.21	286.35
DDA 500H	73.55	406.00	82.38	414.63	94.14	429.53	61.29	338.33	68.65	344.21	78.45	357.94
DDA 600H	105.91	487.19	118.56	489.35	135.53	515.44	88.26	406.00	98.85	412.86	112.97	429.53
DDA 800H	188.29	649.59	210.84	668.52	240.95	687.25	156.91	541.33	175.74	559.96	200.84	572.71
DDA 1000H	294.20	811.99	329.50	844.35	376.58	859.06	245.17	676.66	274.59	698.72	313.81	715.89
DDA 1300H	497.20	1055.59	556.82	1081.18	636.35	1116.78	414.33	879.66	464.05	888.29	530.34	930.65

Note : Intermediate performance with similar E/R ratio are available in between grades.

(R: REACTION FORCE (KN), E: ENERGY ABSORPTION (KNM), TOLERANCE ±10%)

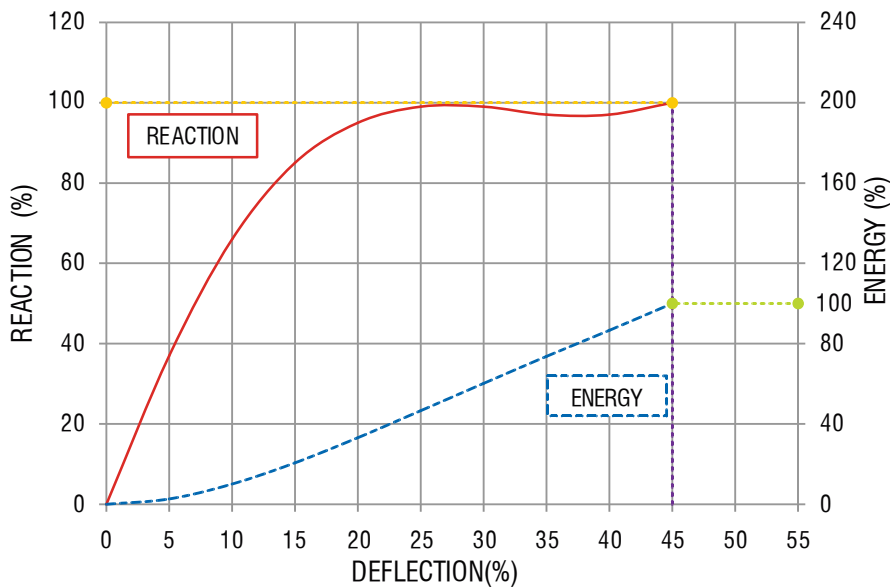

ELEMENT FENDERS SERIES

IRM Element Fenders are efficient buckling type fenders. They are used in pairs and can be arranged in various combinations to optimize the overall performance characteristics of the fender system. They are equipped with fabricated frontal frames and low friction UHMW or HDPE facia pads for vessels requiring a low hull pressure.

These fenders are easy to install and maintain. The replacement cost is low compared to other fenders used for heavy-duty applications. As the system is modular, if there is damage to just one fender element, that single element can be replaced instead of replacing all the fender elements, thereby reducing the replacement cost.

These fenders are extensively used on all types of berthing structures.

IRM offers various models of Element Fenders with different performances to suit the requirements of the various clients.

Key Attributes :

- High performance and efficiency
- Long life, low maintenance
- Multiple choice of lengths and rubber grades
- Low Hull Pressure

Range

Element Fenders can be manufactured in various sizes as per the application and performance requirements.

Applications

- All types of Berths, Jetties and for all types of vessels.

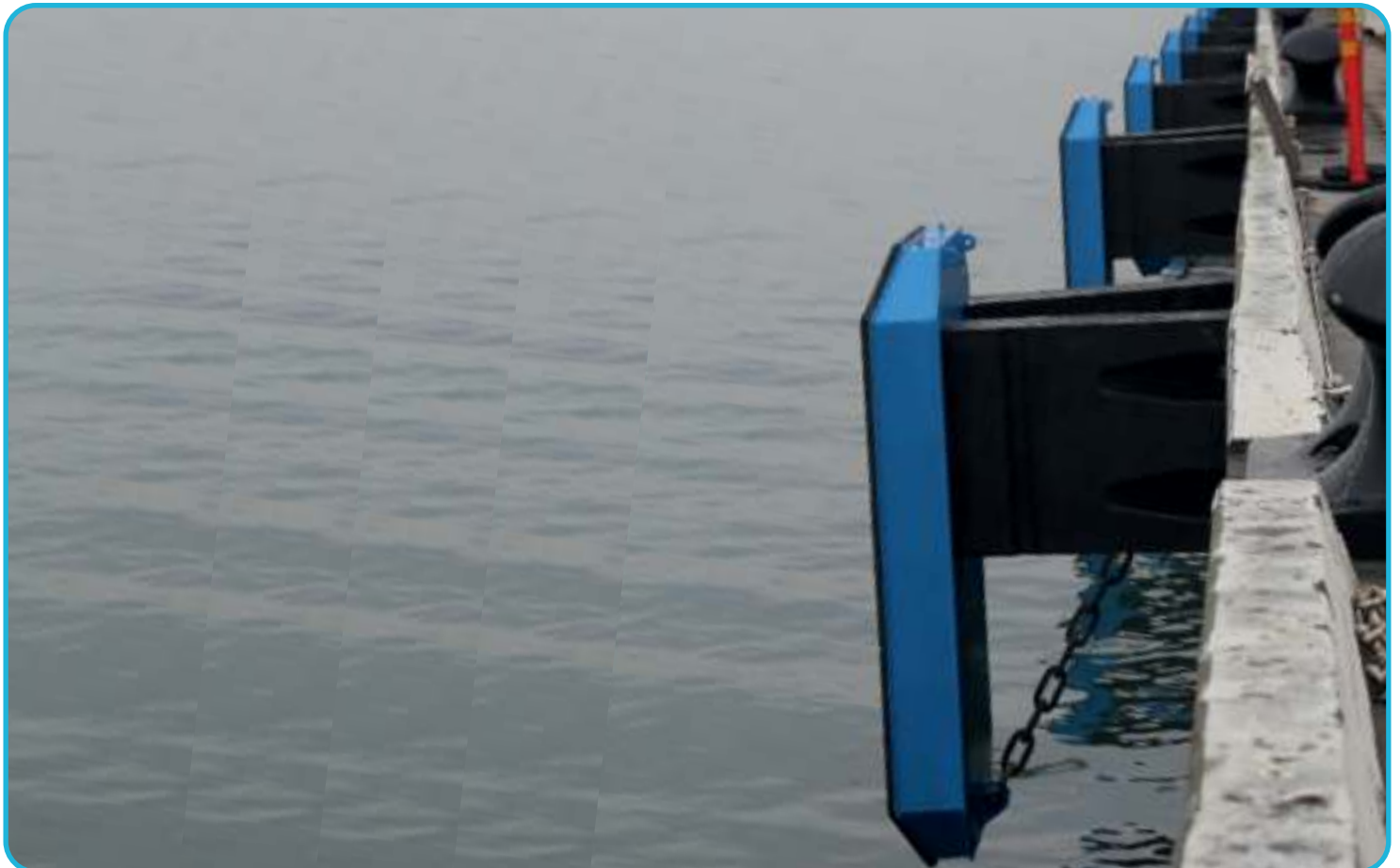

ELEMENT FENDERS SERIES



ELEMENT FENDERS - DI SERIES

DIMENSION TABLE

ALL DIMENSIONS ARE IN MM

MODEL	H	A	P1	P2	S	W	APPROX WEIGHT Kgs./Mtr
DI 400	400	1000	95	405	600	M30	270
DI 600	600	1300	195	555	900	M36	540
DI 800	800	1400	230	490	1000	M36	810
DI 1000	1000	1650	340	560	1250	M42	1150
DI 1400	1400	2190	530	730	1750	M42	1800
DI 1700	1700	2600	580	900	2130	M48	2650
DI 2000	2000	3000	640	1060	2500	M48	3600
DI 2500	2500	3800	900	1300	3120	M56	5250

Weight values are for pair of elements.

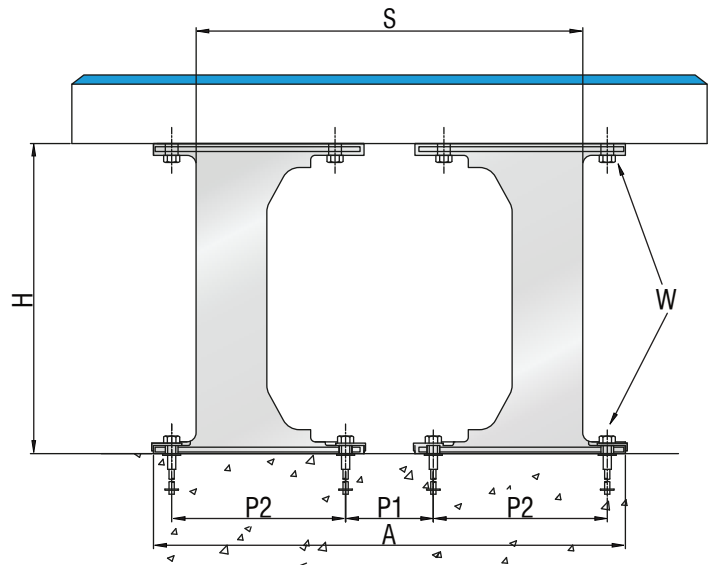
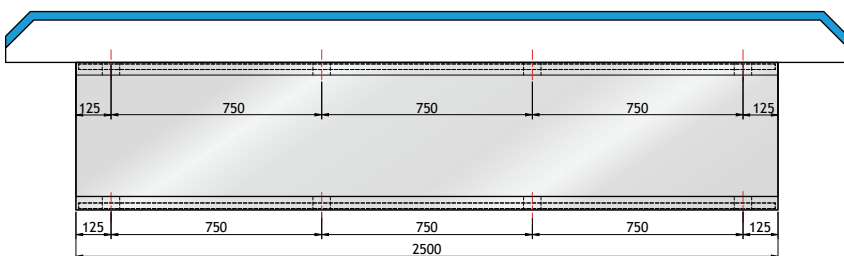
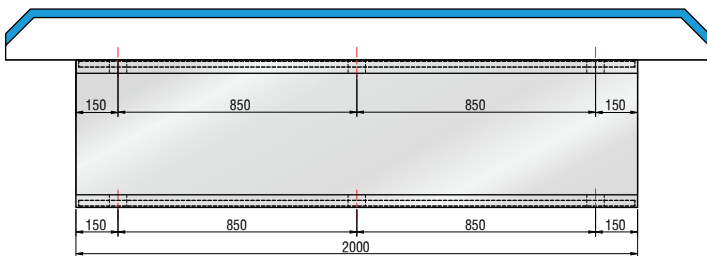
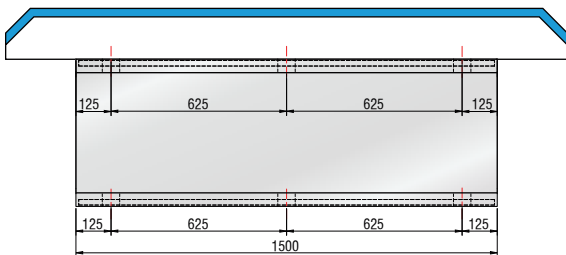
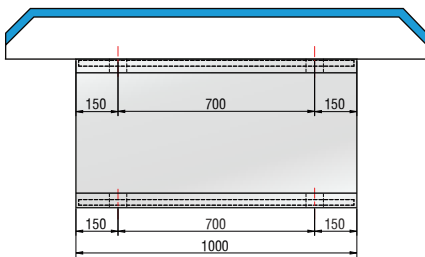

ELEMENT FENDERS - DI SERIES

PERFORMANCE TABLE (Pair of Unit Length)

DEFLECTION	45%		50%	
	E	R	E	R
MODEL				
DI 400H	27.4	188.2	31.3	207.9
DI 600H	61.7	282.4	70.6	311.8
DI 800H	109.8	376.5	125.5	415.8
DI 1000H	171.6	470.7	196.1	519.7
DI 1400H	336.3	659.0	384.4	727.6
DI 1700H	495.2	800.2	566.8	883.5
DI 2000H	686.4	941.4	784.5	1039.5
DI 2500H	1068.9	1176.8	1225.8	1299.3

Note : Intermediate performance with similar E/R ratio are available in between grades.

(R: REACTION FORCE (KN) , E: ENERGY ABSORPTION (KNM), TOLERANCE $\pm 10\%$)

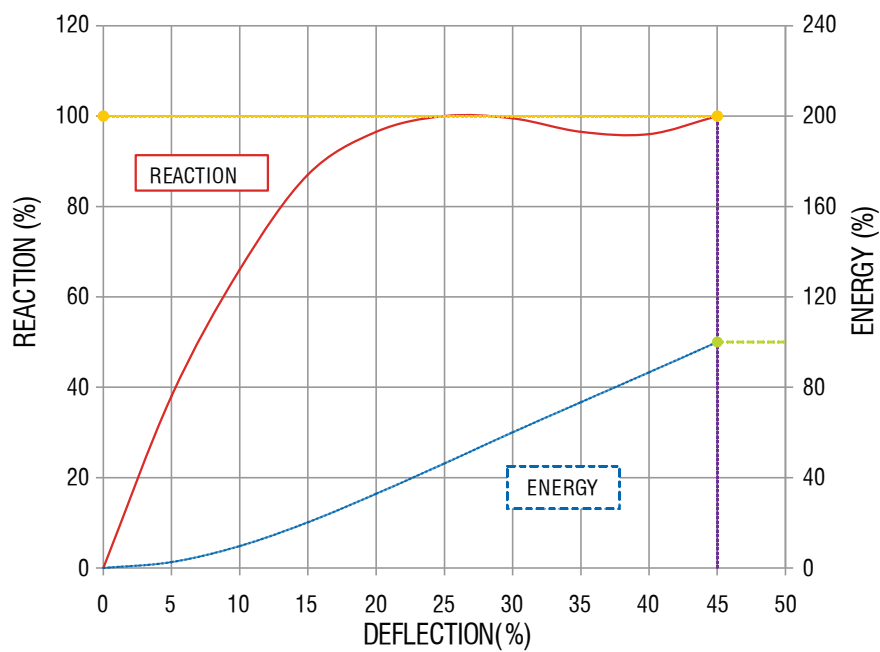

ELEMENT FENDERS - DIV SERIES

DIMENSION TABLE

ALL DIMENSIONS ARE IN MM

MODEL	H	A	B	C	D	W	P	Q	R	K	L	APPROX WEIGHT Kgs/Mtr
DIV 400H	400	1000	100	400	0	M30	300	400	60	180	1000	300
DIV 600H	600	1500	200	500	100	M36	500	400	65	370	1400	600
DIV 800H	800	1500	100	600	100	M36	600	500	70	460	1700	900
DIV 1000H	1000	2000	250	700	100	M42	700	600	75	550	2000	1280
DIV 1150H	1150	2000	220	730	100	M42	730	690	75	580	2150	1520
DIV 1250H	1250	2000	150	800	100	M42	800	700	75	650	2300	1760
DIV 1400H	1400	2500	300	900	100	M42	900	800	85	730	2600	2120
DIV 1700H	1700	3000	375	1050	150	M48	1050	1000	95	860	3100	3020
DIV 2000H	2000	3500	450	1200	200	M48	1200	1200	100	1000	3600	3940
DIV 2500H	2500	4000	500	1400	200	M56	1400	1450	100	1200	4250	5920

Weight values are for pair of elements.

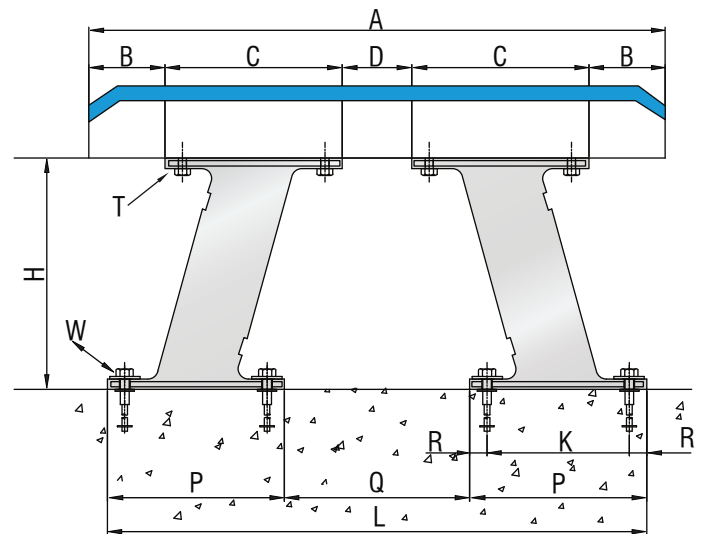
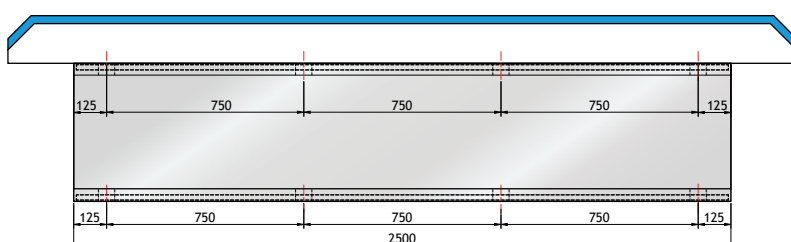
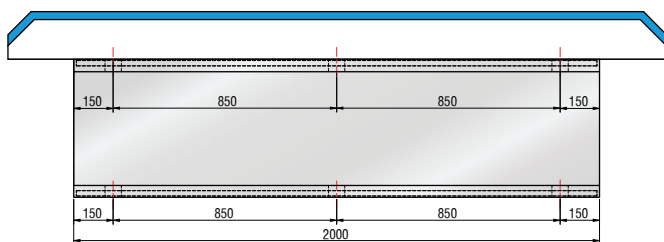
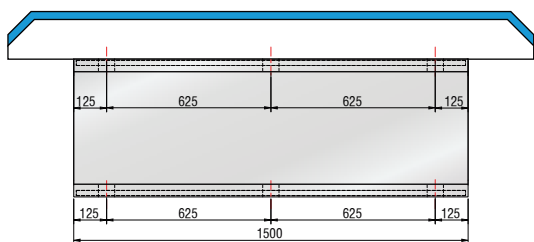
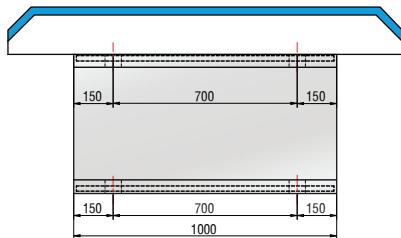

ELEMENT FENDERS - DIV SERIES

PERFORMANCE TABLE (Pair of Unit Length)

MODEL	DEFLECTION	R1		R2		R3		R4		R5	
DIV 400H	52.5%	49.0	323.6	46.0	302.0	39.2	258.8	33.3	215.7	26.4	172.6
	55.0%	52.9	346.1	49.0	323.6	42.1	276.5	35.3	230.4	27.4	184.3
DIV 600H	52.5%	110.8	485.4	103.9	453.0	89.2	388.3	74.5	321.6	58.8	258.9
	55.0%	118.6	524.6	110.8	484.4	95.1	415.8	79.4	346.1	62.7	276.5
DIV 800H	52.5%	198.0	653.1	184.3	599.1	157.8	517.7	131.4	434.4	104.9	344.2
	55.0%	210.8	692.3	197.1	646.2	168.6	554.0	141.2	461.8	111.8	368.7
DIV 1000H	52.5%	337.3	809.0	312.8	755.1	268.7	647.2	223.5	538.3	178.4	431.4
	55.0%	358.9	862.0	332.4	804.1	285.3	689.4	237.3	574.6	190.2	458.9
DIV 1150H	52.5%	446.2	931.6	414.8	868.8	355.0	745.3	296.1	620.7	237.3	495.2
	55.0%	471.7	991.4	440.3	925.7	377.5	793.3	314.7	660.9	252.0	527.6
DIV 1250H	52.5%	523.6	1010.0	489.3	949.2	419.7	809.0	349.1	674.7	274.5	529.5
	55.0%	557.0	1078.7	519.7	1010.0	445.2	862.0	370.6	717.8	299.1	588.4
DIV 1400H	52.5%	657.0	1137.5	613.9	1059.1	525.6	906.1	438.3	755.1	351.0	604.0
	55.0%	698.2	1206.2	651.1	1127.7	558.9	964.9	465.8	804.1	372.6	643.3
DIV 1700H	52.5%	968.9	1372.9	904.1	1284.6	775.7	1098.3	646.2	916.9	516.8	733.5
	55.0%	1039.5	1461.1	961.0	1363.1	823.7	1176.8	686.4	976.7	549.1	781.5
DIV 2000H	52.5%	1343.5	1618.1	1255.2	1510.2	1068.9	1294.4	894.3	1078.7	715.8	862.9
	55.0%	1421.9	1725.9	1333.7	1608.2	1137.5	1382.7	947.3	1147.3	760.0	918.8
DIV 2500H	52.5%	2098.6	2020.1	1961.3	1892.6	1676.9	1618.1	1402.3	1353.3	1117.9	1078.7
	55.0%	2226.1	2157.4	2079.0	2010.3	1784.8	1725.9	1480.8	1441.5	1186.6	1148.3

Note : Intermediate performance with similar E/R ratio are available in between grades.

(R: REACTION FORCE (KN) , E: ENERGY ABSORPTION (KNM), TOLERANCE ±10%)

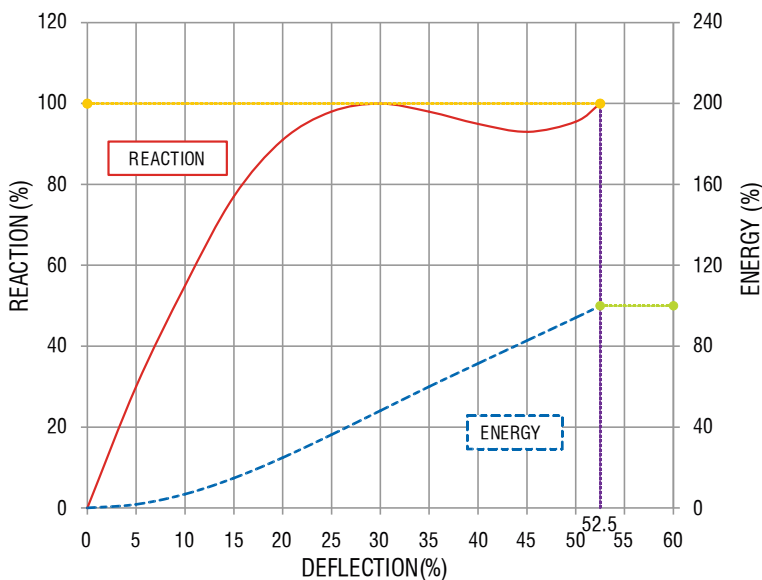

ELEMENT FENDERS - DIVE SERIES

DIMENSION TABLE

ALL DIMENSIONS ARE IN MM

MODEL	H	P	Q	R	S	M	N	O	X	Y	W	APPROX WEIGHT Kgs/Mtr
DIVE 250H	250	107	114	69	20	152	31	214	50	300	M20	64
DIVE 300H	300	130	138	84	25	184	38	250	50	300	M24	88
DIVE 400H	400	160	183	99	25	244	38	320	250	500	M24	190
DIVE 500H	500	195	229	119	30	306	42	390	250	500	M30	264
DIVE 550H	550	210	252	126	32	336	42	420	250	500	M30	324
DIVE 600H	600	225	275	133	35	366	42	450	250	500	M30	350
DIVE 700H	700	270	321	163	35	428	56	540	250	500	M36	520
DIVE 750H	750	285	344	170	38	458	56	570	250	500	M36	590
DIVE 800H	800	300	365	178	38	486	57	600	250	500	M36	630
DIVE 900H	900	335	412	198	42	550	60	670	250	500	M42	810
DIVE 1000H	1000	365	458	212	46	610	60	730	250	500	M42	960
DIVE 1200H	1200	435	557	252	46	748	61	870	250	500	M48	1310
DIVE 1400H	1400	495	641	282	50	856	67	990	250	500	M48	1914
DIVE 1600H	1600	565	733	321	50	978	76	1130	250	500	M56	2450
DIVE 2000H	2000	706	962	355	62	1222	95	1412	250	500	M56	3800

Weight values are for pair of elements.

TYPE 1

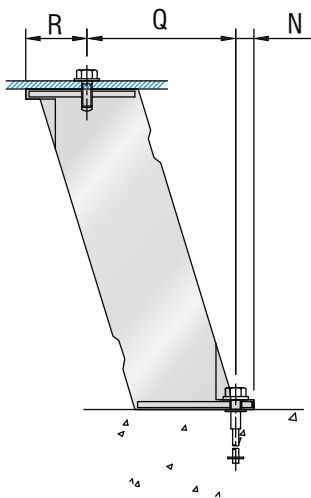

TYPE 2

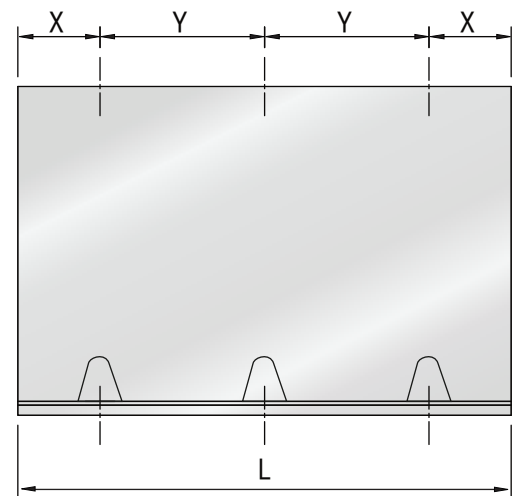
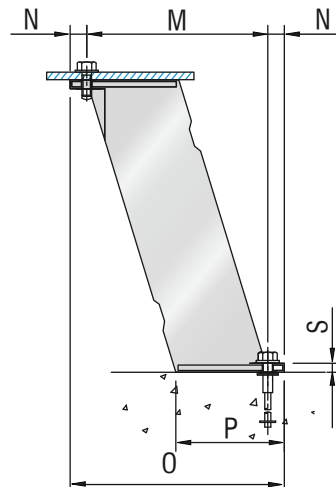

TYPE 1



TYPE 2



ELEMENT FENDERS - DIVE SERIES

PERFORMANCE TABLE (Pair of Unit Length)

MODEL	DEFLECTION	R1		R1.1		R1.2		R1.3		R2		R2.1		R2.2		R2.3		R3		R4	
		E	R	E	R	E	R	E	R	E	R	E	R	E	R	E	R	E	R	E	R
DIVE 250H	57.5%	31.3	319.7	29.4	296.1	27.4	270.6	25.5	247.1	23.5	221.6	22.1	209.8	20.5	198.0	19.6	184.3	17.6	172.6	15.6	154.9
DIVE 300H	57.5%	47.0	378.5	43.1	351.0	41.1	323.6	37.2	294.2	33.3	266.7	31.3	251.0	29.4	237.3	27.4	221.6	25.5	205.9	23.5	186.3
DIVE 400H	57.5%	84.3	460.9	78.4	425.6	72.5	392.2	64.7	356.9	58.8	321.6	54.9	304.0	51.9	284.3	49.0	266.7	45.1	247.1	41.1	221.6
DIVE 500H	57.5%	133.3	576.6	123.5	533.4	113.7	490.3	101.9	445.2	92.1	402.0	86.3	378.5	81.4	356.9	76.4	333.4	70.6	309.8	62.7	278.5
DIVE 550H	57.5%	162.7	633.5	151.0	586.4	137.2	539.3	125.5	490.3	111.8	443.2	105.9	417.7	99.0	392.2	92.1	366.7	86.3	341.2	78.4	307.9
DIVE 600H	57.5%	192.2	690.3	178.4	639.3	162.7	586.4	149.0	535.4	133.3	482.4	125.5	455.0	117.6	427.5	109.8	400.1	101.9	372.6	92.1	335.3
DIVE 700H	57.5%	258.9	810.0	239.2	749.2	219.6	686.4	200.0	625.6	180.4	562.9	170.6	531.5	158.8	498.1	149.0	466.8	137.2	433.4	123.5	390.3
DIVE 750H	57.5%	296.1	868.8	274.5	804.1	253.0	737.4	229.4	672.7	207.9	606.0	196.1	570.7	184.3	537.4	170.6	502.1	158.8	466.8	143.1	419.7
DIVE 800H	57.5%	339.3	921.8	313.8	853.1	288.3	784.5	262.8	713.9	237.3	645.2	223.5	609.9	209.8	574.6	196.1	537.4	182.4	502.1	164.7	447.1
DIVE 900H	57.5%	429.5	1037.5	398.1	959.0	364.8	882.6	333.4	804.1	300.0	725.6	282.4	684.5	266.7	641.3	249.0	600.1	231.4	557.0	207.9	502.1
DIVE 1000H	57.5%	531.5	1151.3	492.2	1065.0	451.1	980.6	411.8	892.4	370.6	806.1	349.1	759.0	329.5	713.9	307.9	666.8	286.3	619.7	256.9	557.0
DIVE 1200H	57.5%	757.0	1384.7	700.1	1280.7	643.3	1174.8	586.4	1070.8	529.5	964.9	498.1	910.0	468.7	853.1	437.3	798.2	406.0	741.3	364.8	666.8
DIVE 1400H	57.5%	1039.5	1614.1	961.0	1492.5	882.6	1372.9	804.1	1249.3	725.6	1127.7	684.5	1063.0	643.3	998.3	602.1	931.6	560.9	866.9	504.0	780.6
DIVE 1600H	57.5%	1359.2	1841.6	1257.2	1704.4	1155.2	1567.1	1051.2	1427.8	949.2	1290.5	896.3	1216.0	841.4	1141.4	788.4	1066.9	733.5	992.4	660.9	892.4
DIVE 2000H	66%	2049.5	1918.1	1904.4	1780.8	1757.3	1643.5	1610.2	1506.3	1465.1	1369.0	1318.0	1231.7	1170.9	1096.3	1025.7	959.0	878.6	821.8	731.5	684.5

Note : Intermediate performance with similar E/R ratio are available in between grades.

(R: REACTION FORCE (KN) , E: ENERGY ABSORPTION (KJM), TOLERANCE ±10%)

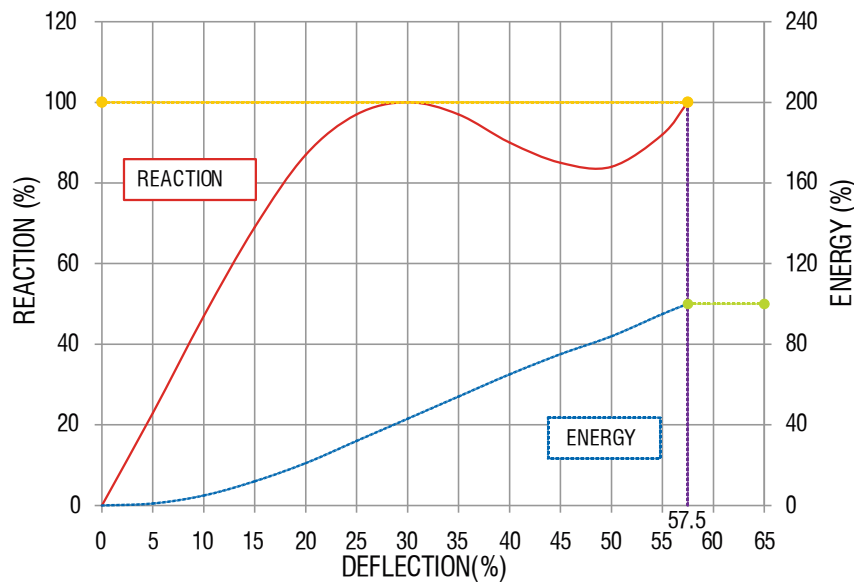

ELEMENT FENDERS - DIVSE SERIES

DIMENSION TABLE

ALL DIMENSIONS ARE IN MM

MODEL	H	A	B	C	T	X	Y	BOLTS	APPROX WEIGHT Kgs/Mtr
DIVSE 250H	250	74	37.5	93.5	15	50	300	M20	64
DIVSE 300H	300	94	47	93	17	50	300	M20	92
DIVSE 400H	400	125	63	124	17	250	500	M24	132
DIVSE 500H	500	158	87	142	20	250	500	M30	222
DIVSE 550H	550	172	87	170	20	250	500	M30	264
DIVSE 600H	600	188	87	199	20	250	500	M30	306
DIVSE 750H	750	235	118	230	26	250	500	M36	478
DIVSE 800H	800	250	129	240	26	250	500	M36	536
DIVSE 1000H	1000	322	162	310	31	250	500	M42	864
DIVSE 1250H	1250	401	202	388	36	250	500	M48	1278
DIVSE 1450H	1450	454	228	445	41	250	500	M48	1746
DIVSE 1600H	1600	507	261	480	50	250	500	M56	2228

Weight values are for pair of elements.

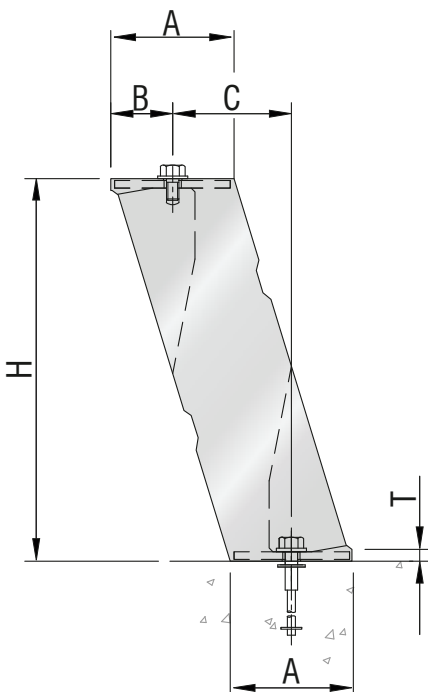

TYPE 1

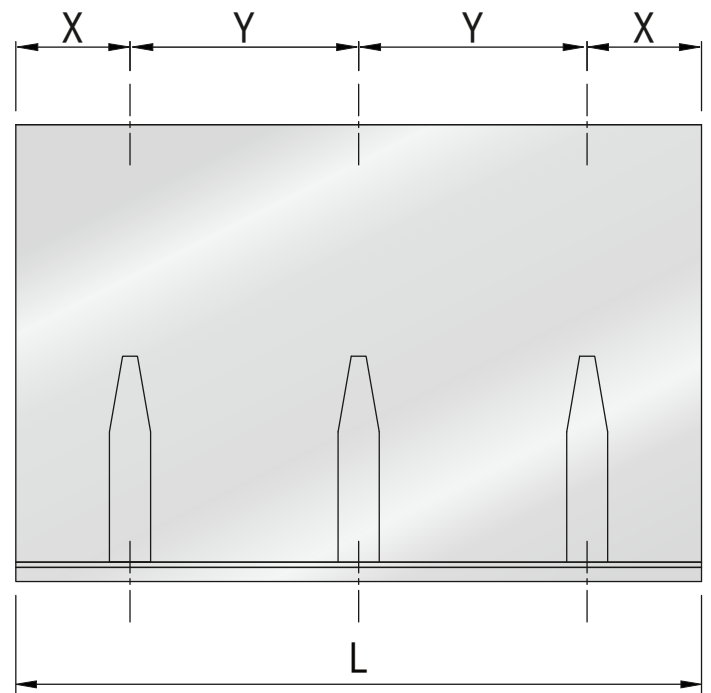
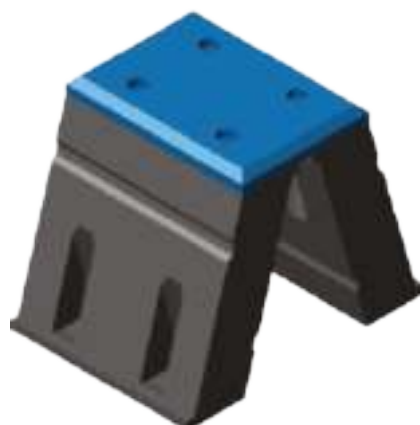

TYPE 2



ELEMENT FENDERS - DIVSE SERIES

PERFORMANCE TABLE (Pair of Unit Length)

MODEL	DEFLECTION	R1		R1.1		R2		R2.1		R3		R3.1	
		E	R	E	R	E	R	E	R	E	R	E	R
DIVSE 250H	57.5%	29.4	253.0	25.5	247.1	23.5	219.6	21.5	176.5	17.6	172.6	15.6	154.9
DIVSE 300H	57.5%	41.1	305.9	39.2	294.2	33.3	258.9	29.4	213.7	25.5	203.9	21.5	186.3
DIVSE 400H	57.5%	74.5	406.0	68.6	402.0	58.8	313.8	52.9	284.3	43.1	245.1	39.2	219.6
DIVSE 500H	57.5%	117.6	507.9	109.8	500.1	84.3	394.2	82.3	355.0	68.6	307.9	58.8	274.5
DIVSE 550H	57.5%	141.2	557.0	137.2	549.1	103.9	435.4	98.0	392.2	84.3	339.3	78.4	304.0
DIVSE 600H	57.5%	168.6	609.9	160.8	608.0	125.5	474.6	117.6	425.6	98.0	368.7	90.2	333.4
DIVSE 750H	57.5%	262.8	761.0	254.9	753.1	200.0	598.2	184.3	533.4	156.9	462.8	139.2	415.8
DIVSE 800H	57.5%	300.0	811.9	294.2	808.0	229.4	637.4	209.8	568.7	178.4	498.1	160.8	443.2
DIVSE 1000H	57.5%	468.7	1015.9	460.9	1008.1	362.8	798.2	327.5	711.9	284.3	615.8	254.9	557.0
DIVSE 1250H	57.5%	729.6	1268.9	721.7	1261.1	560.9	957.1	511.9	888.4	400.1	737.4	360.8	662.9
DIVSE 1450H	57.5%	982.6	1471.0	974.7	1369.0	737.4	1119.9	688.4	1031.6	557.0	862.9	500.1	776.6
DIVSE 1600H	57.5%	1196.4	1625.9	1168.9	1618.1	941.4	1282.7	837.4	1137.5	729.6	988.5	657.0	888.4

Note : Intermediate performance with similar E/R ratio are available in between grades.

(R: REACTION FORCE (KN) , E: ENERGY ABSORPTION (KNM), TOLERANCE ±10%)

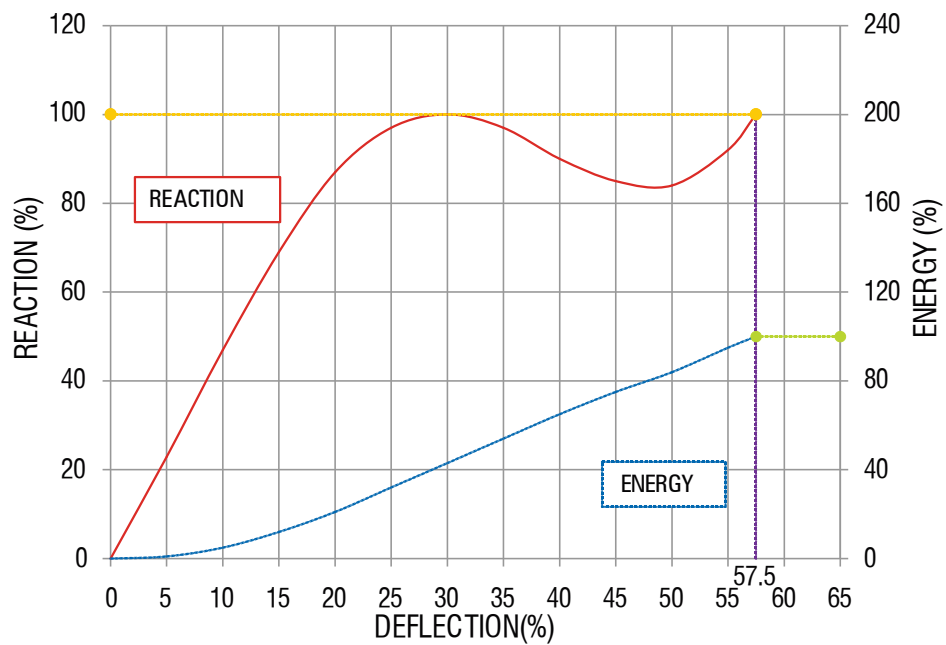

ELEMENT FENDERS - DIVM SERIES

DIMENSION TABLE

ALL DIMENSIONS ARE IN MM

MODEL	H	A	B	C	D	M	F	I	J	K	L	W	T	APPROX WEIGHT Kgs/Mtr
DIVM 600H	600	1400	760	500	400	370	330	100	65	370	530	M36	M24	545
DIVM 800H	800	1700	920	600	500	460	410	100	70	460	640	M36	M24	825
DIVM 1000H	1000	2000	1060	700	600	550	480	100	75	550	750	M42	M30	1185
DIVM 1150H	1150	2150	1130	730	690	580	515	100	75	550	750	M42	M30	1480
DIVM 1250H	1250	2300	1220	800	700	650	560	100	75	650	850	M42	M30	1695
DIVM 1400H	1400	2600	1360	900	800	730	630	100	85	730	970	M42	M36	2065
DIVM 1700H	1700	3100	1650	1050	1000	860	750	150	95	860	1190	M48	M36	2930
DIVM 2000H	2000	3600	1920	1200	1200	1000	860	200	100	1000	1400	M48	M42	4005
DIVM 2500H	2500	4200	2240	1400	1400	1200	1020	200	100	1200	1650	M56	M48	5755

Weight values are for pair of elements.

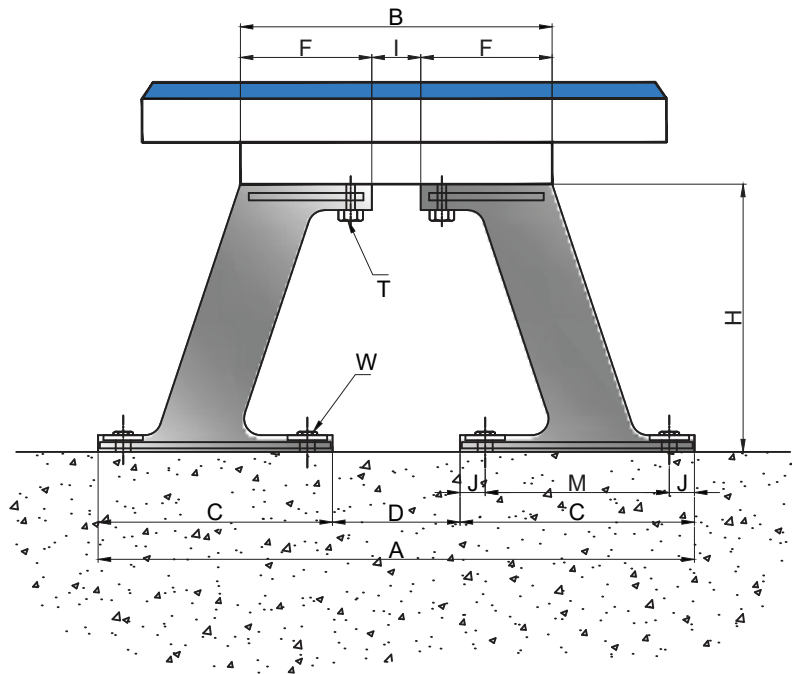
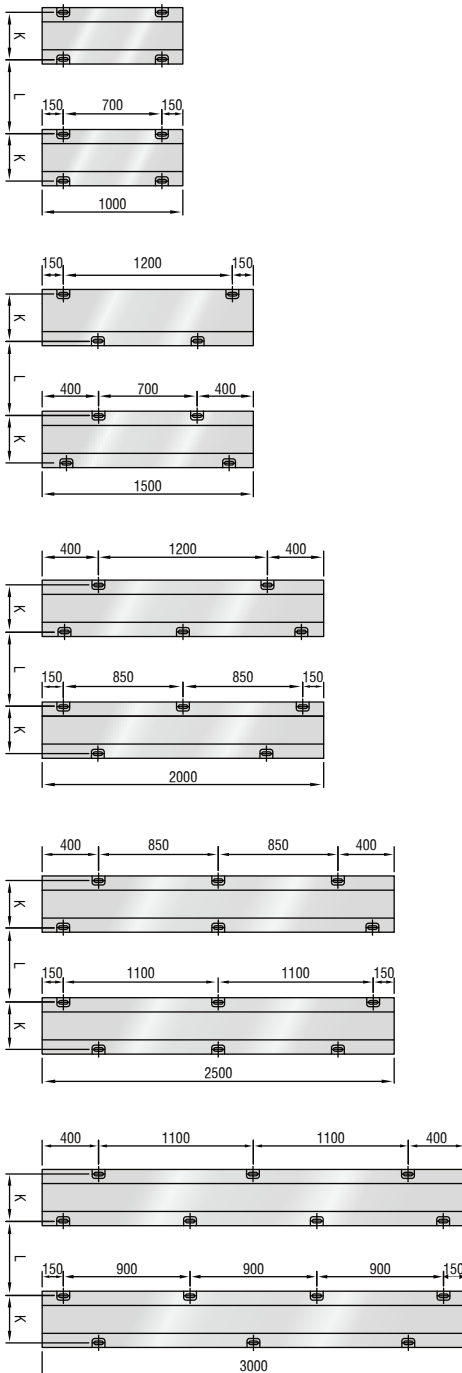

ELEMENT FENDERS - DIVM SERIES

PERFORMANCE TABLE (Pair of Unit Length)

MODEL	DEFLECTION	R1		R2		R3		R4	
		E	R	E	R	E	R	E	R
DIVM 600H	60.0%	130.4	456.0	121.6	426.5	104.9	364.8	87.2	325.5
	62.5%	137.2	490.3	128.4	458.9	110.8	392.2	93.1	330.4
DIVM 800H	60.0%	230.4	609.9	223.5	566.8	185.3	491.3	154.9	407.9
	62.5%	243.2	658.0	226.5	619.7	197.1	524.6	163.7	440.3
DIVM 1000H	60.0%	359.9	761.9	335.3	710.9	289.3	609.9	244.1	509.9
	62.5%	378.5	823.7	354.0	768.8	305.9	658.0	253.0	551.1
DIVM 1150H	60.0%	475.6	877.7	446.2	818.8	377.5	701.1	315.7	586.4
	62.5%	503.0	950.2	465.8	883.5	400.1	755.1	335.3	633.5
DIVM 1250H	60.0%	560.9	954.1	524.6	888.4	449.1	762.9	377.5	637.4
	62.5%	590.3	1031.6	554.0	963.0	472.6	824.7	399.1	688.4
DIVM 1400H	60.0%	702.1	1066.9	656.0	997.3	563.8	858.0	465.8	713.9
	62.5%	740.4	1152.2	691.3	1074.8	591.3	920.8	493.2	770.8
DIVM 1700H	60.0%	1034.6	1298.4	965.9	1211.1	829.6	1036.5	692.3	866.9
	62.5%	1091.4	1400.3	1017.9	1308.2	871.8	1121.8	732.5	936.5
DIVM 2000H	60.0%	1430.7	1527.8	1338.6	1424.9	1145.4	1220.9	957.1	1019.8
	62.5%	1509.2	1650.4	1409.2	1539.6	1209.1	1319.9	1006.1	1101.2
DIVM 2500H	60.0%	2236.9	1910.3	2084.8	1784.8	1789.7	1527.8	1493.5	1274.8
	62.5%	2354.5	2064.3	2196.6	1922.1	1885.8	1649.4	1572.9	1376.8

Note : Intermediate performance with similar E/R ratio are available in between grades.

(R: REACTION FORCE (KN) , E: ENERGY ABSORPTION (KNM), TOLERANCE ±10%)

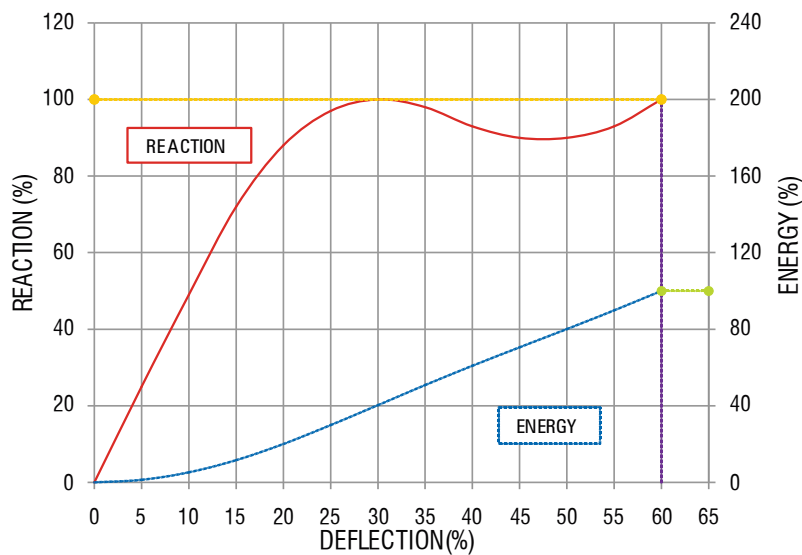

ELEMENT FENDERS

CORRECTION FACTORS

ENERGY

Velocity Correction Factor-Energy Absorption	
Berthing Velocity (M/sec)	Correction Factor
0.001	0.950
0.050	0.995
0.100	1.009
0.150	1.000
0.200	1.011
0.250	1.020
0.300	1.030

REACTION

Velocity Correction Factor-Reaction Force	
Berthing Velocity (M/sec)	Correction Factor-
0.001	0.957
0.050	0.999
0.100	1.009
0.150	1.000
0.200	1.012
0.250	1.022
0.300	1.040

Temperature Correction Factor-Energy Absorption	
Temperature (Deg C)	Correction Factor
-30	1.087
-20	1.066
-10	1.054
0	1.045
10	1.031
20	1.021
23	1.000
30	0.993
40	0.990
50	0.985

Temperature Correction Factor-Reaction Force	
Temperature (Deg C)	Reaction Correction Factor
-30	1.175
-20	1.162
-10	1.09
0	1.08
10	1.07
20	1.05
23	1.000
30	0.995
40	0.989
50	0.980

Angular Correction Factor - Energy Absorption	
Berthing Angle(Degree)	Correction Factor
0	1.000
3	0.990
5	0.980
8	0.970
10	0.960
15	0.950
20	0.920

Note : The above correction factors are applicable to Element fenders DI, DIV, DIVE, DIVSE, DIVM series.

HIGH PERFORMANCE FENDERS

CELL FENDERS - DC SERIES

IRM DC series Cell Fenders are best employed for large size vessels, where higher energy absorption and lower reaction force is important criteria. The basic design of the Cell Fender gives sturdiness, good shear resistance and the capacity to absorb energy equally from all directions. The cylindrical buckling column absorbs axial loads effectively and buckles radially.

These fenders are equipped with frontal frames with low friction UHMW-PE fascia pads to reduce the shear force and the hull pressure. Cell Fenders can be installed in single, dual or in combination with a common frontal frame for optimization of the performance characteristics. This facility to fit extended frames provides a large vertical contact area for ports with a high tidal variation. Cell Fenders are one of the most preferred fenders for large-sized vessels where hull pressure requirements are quite stringent.

Key Attributes :

- Lower reaction.
- Lower hull pressure.
- Multi directional dispersion of energy.
- Can support large panels.
- Excellent durability.

Range

DC series Cell Fenders are available from 400 mm height to 3000 height and are supplied with suitable Frontal Frames and Chains.

Applications

DC series Cell Fenders are employed in various berthing applications and different types of construction.



CELL FENDERS - DC SERIES



CELL FENDERS - DC SERIES

DIMENSIONTABLE

ALL DIMENSIONS ARE IN MM

MODEL	A	ØB	ØC	D	F		APPROXWEIGHT Kgs
					R-1 to R-3.3	R-4 to R-5.1	
DC 400H	400	550	650	25	4 x M22	4 x M22	75
DC 500H	500	550	650	25	4 x M22	4 x M22	95
DC 630H	630	700	840	25	4 x M24	4 x M22	220
DC 800H	800	900	1050	30	6 x M24	6 x M22	400
DC 1000H	1000	1100	1300	35	6 x M30	6 x M27	790
DC 1150H	1150	1300	1500	37	6 x M36	6 x M30	1200
DC 1250H	1250	1450	1650	40	6 x M36	6 x M30	1500
DC 1450H	1450	1650	1850	42	6 x M42	6 x M36	2300
DC 1600H	1600	1800	2000	45	8 x M42	8 x M36	3000
DC 1700H	1700	1900	2100	50	8 x M42	8 x M36	3700
DC 2000H	2000	2000	2200	50	8 x M48	8 x M42	5000
DC 2250H	2250	2300	2550	57	10 x M56	10 x M48	7400
DC 2500H	2500	2700	2950	70	10 x M56	10 x M48	10700
DC 3000H	3000	3150	3350	75	12 x M64	12 x M56	18500

Note : Weight values mentioned are approximate.

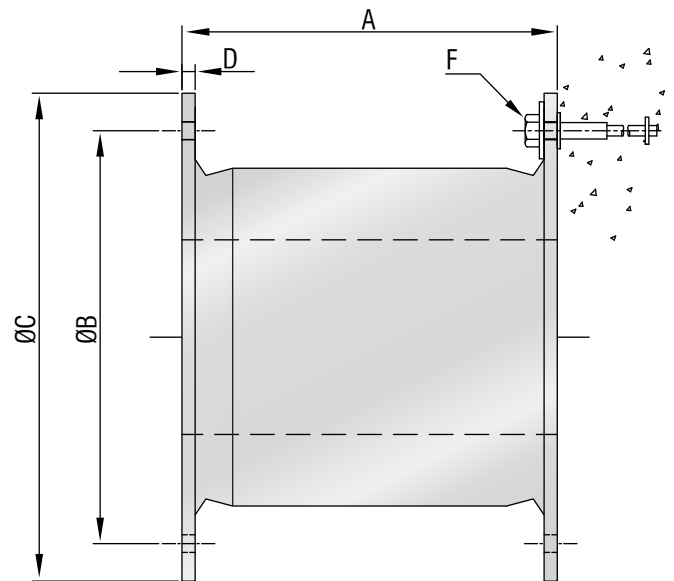
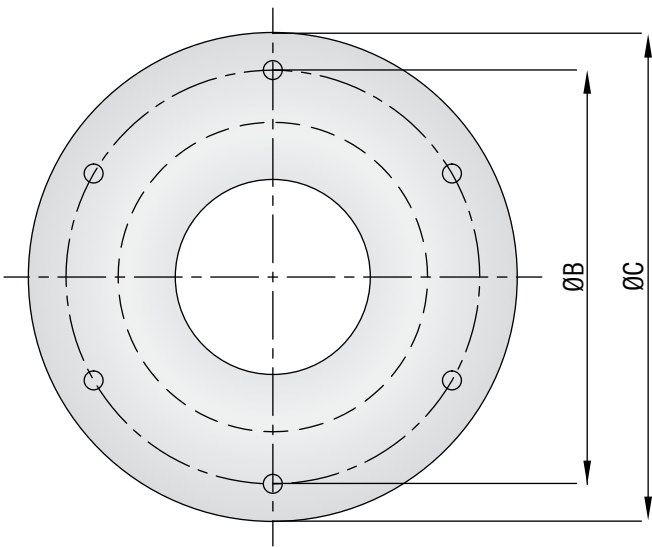

CELL FENDERS - DC SERIES

PERFORMANCE TABLE

MODEL	DEFLECTION	R1.0		R1.1		R1.2		R1.3		R2.0		R2.1		R2.2		R2.3		R3.0	
		E	R	E	R	E	R	E	R	E	R	E	R	E	R	E	R	E	R
DC 400H	52.5%	26.4	153.9	25.5	148.0	24.5	142.2	23.5	136.3	22.5	131.4	21.5	125.5	20.5	119.6	19.6	113.7	18.6	108.8
DC 500H	52.5%	49.0	233.4	48.0	224.5	46.0	215.7	44.1	207.9	42.1	199.0	40.2	191.2	38.2	182.4	37.2	173.5	35.3	165.7
DC 630H	52.5%	100.0	361.8	96.1	348.1	93.1	335.3	89.2	322.6	85.3	296.1	82.3	361.8	78.4	282.4	74.5	269.6	70.6	255.9
DC 800H	52.5%	203.0	580.5	195.1	557.0	187.3	534.4	179.4	511.9	170.6	488.3	162.7	465.8	154.9	442.2	147.1	419.7	139.2	397.1
DC 1000H	52.5%	398.1	926.7	383.4	891.4	367.7	856.1	353.0	819.8	337.3	784.5	321.6	749.2	306.9	712.9	291.2	677.6	276.5	642.3
DC 1150H	52.5%	592.1	1182.6	568.7	1137.5	546.2	1092.4	523.6	1048.3	501.1	1003.2	479.5	958.1	456.9	913.0	434.4	868.8	411.8	823.7
DC 1250H	52.5%	764.9	1530.8	736.4	1471.9	707.0	1414.1	677.6	1356.2	649.2	1239.5	619.7	1239.5	590.3	1180.7	561.9	1122.8	532.5	1065.0
DC 1450H	52.5%	1183.6	1860.3	1138.5	1860.3	1093.4	1719.1	1049.3	1649.4	1004.2	1578.8	959.0	1508.2	913.9	1437.6	869.8	1367.0	824.7	1296.4
DC 1600H	52.5%	1590.6	2272.2	1530.8	2186.8	1470.0	2100.5	1410.2	2014.2	1350.3	1928.9	1289.5	1842.6	1229.7	1756.3	1168.9	1670.0	1109.1	1584.7
DC 1700H	52.5%	1908.3	2578.1	1835.8	2480.1	1763.2	2383.0	1690.6	2284.9	1619.0	2187.8	1546.5	2089.8	1473.9	1991.7	1402.3	1894.6	1329.7	1796.5
DC 2000H	52.5%	3063.6	3477.4	2948.8	3347.0	2833.1	3215.6	2718.4	3085.1	2602.6	2954.7	2487.9	2823.3	2372.2	2692.9	2257.4	2561.5	2141.7	2431.0
DC 2250H	52.5%	4818.9	4917.0	4644.4	4739.5	4470.2	4561.0	4296.2	4383.5	4121.7	4206.0	3947.1	4027.5	3772.6	3850.0	3598.0	3671.6	3424.4	3494.1
DC 2500H	52.5%	6549.8	6008.5	6313.5	5792.7	6078.1	5576.0	5842.8	5360.3	5607.4	5143.5	5371.1	4927.8	5135.7	4711.1	4900.3	4495.3	4664.0	4279.6
DC 3000H	52.5%	9789.9	8296.4	9436.9	7997.3	9084.8	7699.2	8731.8	7400.1	8378.8	7101.0	8026.7	6801.8	7673.7	6502.7	7320.6	6203.6	6967.6	5905.5

Note : Intermediate performance with similar E/R ratio are available in between grades.

(R: REACTION FORCE (KN) , E: ENERGY ABSORPTION (KNM), TOLERANCE ±10%)

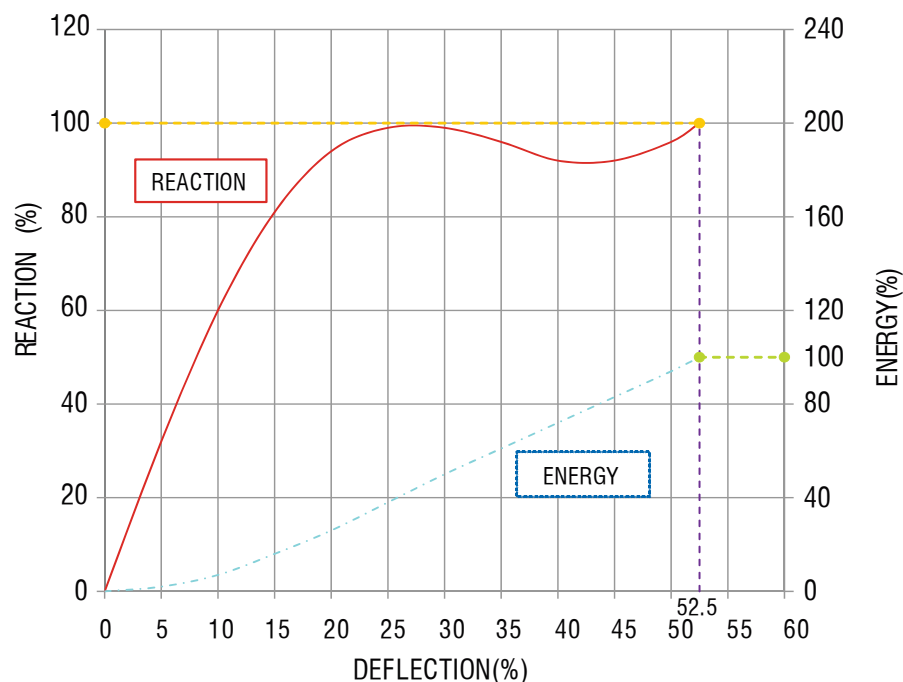

CELL FENDERS - DC SERIES

PERFORMANCE TABLE

MODEL	DEFLECTION	R3.1		R3.2		R3.3		R4.0		R4.1		R4.2		R4.3		R5.0		R5.1	
		E	R	E	R	E	R	E	R	E	R	E	R	E	R	E	R	E	R
DC 400H	52.5%	17.6	102.9	16.6	97.0	15.6	92.1	14.7	86.3	13.7	80.4	12.7	74.5	11.7	69.6	10.7	63.7	8.8	50.0
DC 500H	52.5%	33.3	156.9	31.3	148.0	29.4	140.2	27.4	131.4	26.4	123.5	24.5	114.7	22.5	105.9	20.5	98.0	16.6	78.4
DC 630H	52.5%	67.6	243.2	63.7	229.4	59.8	216.7	55.9	203.0	52.9	176.5	49.0	243.2	45.1	163.7	42.1	151.0	34.3	123.5
DC 800H	52.5%	130.4	373.6	122.5	351.0	114.7	328.5	106.8	304.9	99.0	282.4	91.2	259.8	82.3	236.3	74.5	213.7	66.6	190.2
DC 1000H	52.5%	260.8	607.0	245.1	570.7	230.4	535.4	214.7	500.1	200.0	463.8	184.3	428.5	168.6	393.2	153.9	357.9	137.2	319.7
DC 1150H	52.5%	389.3	778.6	366.7	733.5	344.2	689.4	321.6	644.3	300.0	599.1	277.5	554.0	254.9	509.9	232.4	464.8	209.8	419.7
DC 1250H	52.5%	503.0	1006.1	473.6	948.3	445.2	889.4	415.8	831.6	386.3	772.7	357.9	714.9	328.5	657.0	299.1	598.2	268.7	537.4
DC 1450H	52.5%	779.6	1225.8	735.5	1225.8	690.3	1085.6	645.2	1014.9	601.1	944.3	556.0	873.7	510.9	803.1	465.8	732.5	420.7	661.9
DC 1600H	52.5%	1049.3	1498.4	988.5	1412.1	928.6	1326.8	867.8	1240.5	808.0	1154.2	748.2	1067.9	687.4	982.6	627.6	896.3	565.8	808.0
DC 1700H	52.5%	1257.2	1699.4	1185.6	1601.4	1113.0	1504.3	1040.4	1406.2	967.9	1308.2	896.3	1211.1	823.7	1113.0	751.1	1015.9	677.6	915.9
DC 2000H	52.5%	2027.0	2300.6	1911.3	2169.2	1796.5	2038.8	1680.8	1908.3	1566.1	1776.9	1450.4	1646.5	1335.6	1516.1	1219.9	1384.7	1103.2	1252.3
DC 2250H	52.5%	3249.9	3315.6	3075.3	3138.1	2900.8	2960.6	2726.2	2782.1	2552.6	2604.6	2378.1	2426.1	2203.5	2248.6	2029.0	2070.1	1853.4	1891.7
DC 2500H	52.5%	4428.6	4062.9	4193.3	3847.1	3956.9	3630.4	3721.6	3414.6	3486.2	3197.9	3250.9	2982.2	3014.5	2765.4	2779.2	2549.7	2542.8	2333.0
DC 3000H	52.5%	6615.5	5606.4	6262.5	5307.3	5909.4	5008.2	5557.4	4709.1	5204.3	4410.0	4851.3	4111.9	4499.2	3812.8	4146.2	3513.7	3793.2	3214.6

Note : Intermediate performance with similar E/R ratio are available in between grades.

(R: REACTION FORCE (KN) , E: ENERGY ABSORPTION (KNM), TOLERANCE ±10%)



CELL FENDERS - DC SERIES

CORRECTION FACTORS

ENERGY

Velocity Correction Factor-Energy Absorption	
Berthing Velocity (M/sec)	Correction Factor-Energy Absorption
0.001	0.944
0.050	0.989
0.100	0.995
0.150	1.000
0.200	1.002
0.250	1.003
0.300	1.008

REACTION

Velocity Correction Factor-Reaction Force	
Berthing Velocity (M/sec)	Correction Factor-Reaction Force
0.001	0.974
0.050	0.990
0.100	0.993
0.150	1.000
0.200	1.001
0.250	1.005
0.300	1.010

Temperature Correction Factor-Energy Absorption	
Temperature (Deg C)	Energy Absorption Correction Factor
-30	1.342
-20	1.35
-10	1.381
0	1.189
10	1.132
20	1.047
23	1.000
30	1.024
40	0.972
50	0.996

Temperature Correction Factor-Reaction Force	
Temperature (Deg C)	Reaction Correction Factor
-30	1.147
-20	1.143
-10	1.136
0	1.084
10	1.067
20	1.032
23	1.000
30	1.001
40	0.997
50	0.985

Angular Correction Factor - Energy Absorption	
Berthing Angle(Degree)	Energy Absorption Correction Factor
0	1.000
3	0.963
5	0.961
8	0.936
10	0.905
15	0.814
20	0.705

CONE FENDERS - DCN SERIES

IRM DCN Series Cone Fenders are compact fenders compared to Cell Fenders. They have a higher Energy Absorption capacity for the same height, which is mainly due to the conical shape, which allows deflection up to 72%. This advanced feature of Cone Fenders improves the material handling capabilities of the deck/vessel cranes and reduces the project's overall cost. Cone Fenders are also more stable at large compression angles and offer better shear resistance compared to any other fenders.

Like Cell Fenders, Cone Fenders can also be equipped with frontal frames fitted with low friction UHMW-PE fascia pads to reduce the shear force and the hull pressure. Cone Fenders can be installed in single, dual or in combination with a common frontal frame for optimizing the performance characteristics. These fenders are fitted with extended frames to provide a larger contact area vertically for ports with a high tidal variation.

Key Attributes :

- Highly effective profile providing maximum efficiency
- Stable shape resists shear force
- Deflection up to 72%
- Can be reverse mounted for a smaller footprint
- Good Durability

Range

DCN Series Cone Fenders are available from 300 mm height to 2500 height and are supplied with suitable Frontal Frames and Chains.

Applications

DCN Series Cone Fenders are found in various berthing applications and different types of construction

- All types of berths and Jetties



CONE FENDERS - DCN SERIES



CONE FENDERS - DCN SERIES

DIMENSION TABLE

ALL DIMENSIONS ARE IN MM

MODEL	A	ØB	ØC	ØD	ØE	F & G		T	APPROX WEIGHT Kgs
						BOLT FOR	BOLT FOR		
						R1 TO R2,3	R3 TO R4		
DCN 300H	300	500	295	440	255	4 x M16	4 x M16	15	35
DCN 350H	350	570	330	510	275	4 x M16	4 x M16	15	45
DCN 400H	400	650	390	585	340	4 x M20	4 x M16	20	75
DCN 500H	500	800	490	730	425	4 x M24	4 x M20	25	145
DCN 550H	550	880	540	790	470	4 x M24	4 x M20	25	195
DCN 600H	600	960	590	875	515	4 x M30	4 x M20	30	250
DCN 700H	700	1120	685	1020	600	4 x M30	4 x M24	35	400
DCN 800H	800	1280	785	1165	685	6 x M30	6 x M24	35	610
DCN 900H	900	1440	885	1313	770	6 x M30	6 x M30	35	850
DCN 1000H	1000	1600	980	1460	855	6 x M36	6 x M30	35	1125
DCN 1050H	1050	1680	1030	1530	900	6 x M36	6 x M30	40	1365
DCN 1100H	1100	1760	1080	1605	940	8 x M36	8 x M30	40	1550
DCN 1200H	1200	1920	1175	1750	1025	8 x M42	8 x M36	40	1975
DCN 1300H	1300	2080	1275	1900	1100	8 x M42	8 x M36	40	2460
DCN 1400H	1400	2240	1370	2040	1195	8 x M42	8 x M36	50	3110
DCN 1600H	1600	2560	1570	2335	1365	8 x M48	8 x M42	60	4650
DCN 1800H	1800	2880	1765	2625	1540	10 x M56	10 x M48	60	6620
DCN 2000H	2000	3200	1955	2920	1710	10 x M56	10 x M48	90	9560
DCN 2250H	2250	3600	2205	3285	1930	12 x M56	12 x M48	105	13500
DCN 2500H	2500	4000	2450	3650	2150	12 x M64	12 x M56	120	18500

Note : Weight values mentioned are approximate.

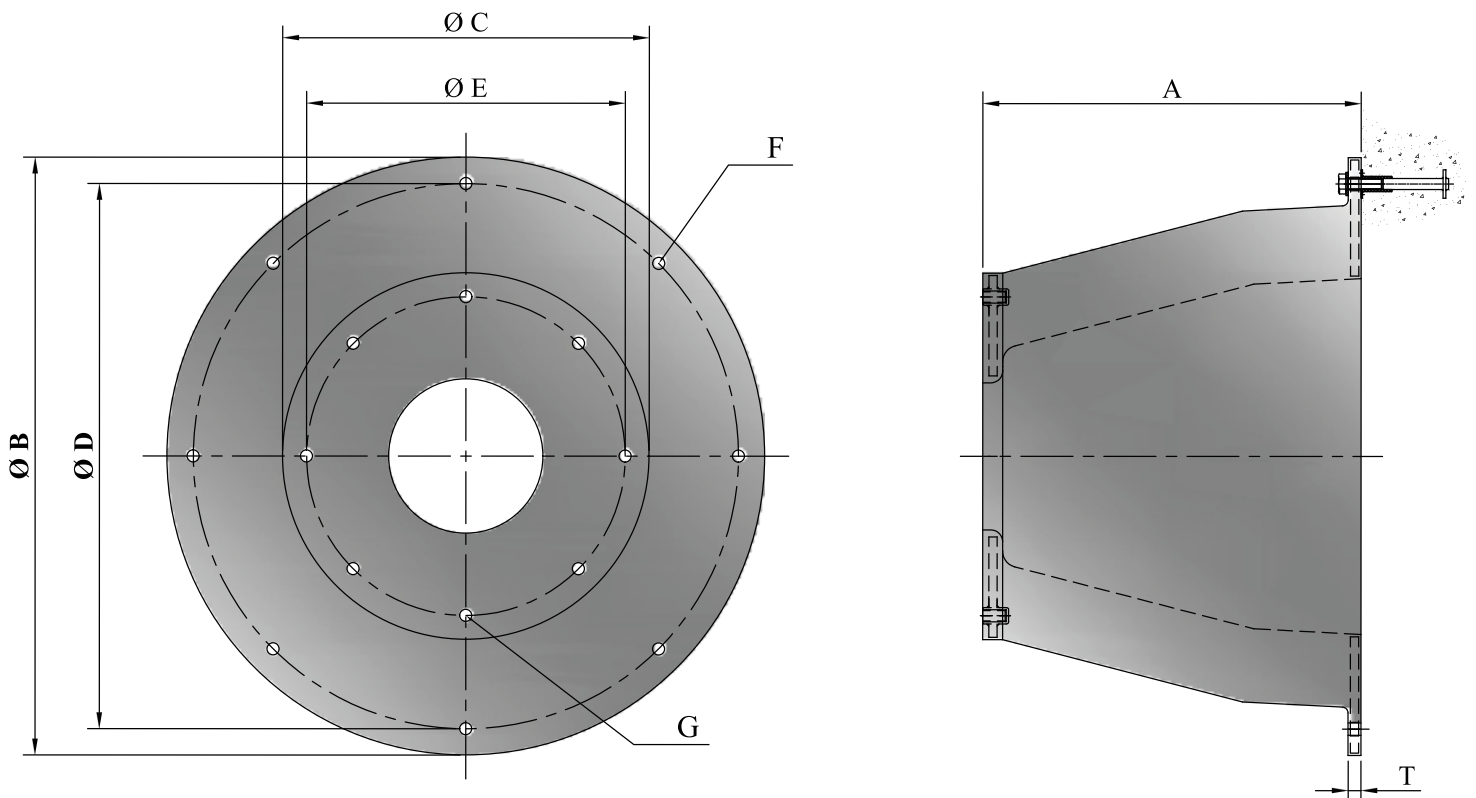

CONE FENDERS - DCN SERIES

PERFORMANCE TABLE

MODEL	DEFLECTION	R1		R1.1		R1.2		R1.3		R2		R2.1		R2.2	
		E	R	E	R	E	R	E	R	E	R	E	R	E	R
DCN 300H	72.0%	19.6	110.8	18.6	105.9	17.6	101.0	16.6	94.1	15.6	87.2	14.7	81.4	13.7	75.5
DCN 350H	72.0%	31.3	151.0	30.4	144.1	28.4	138.2	26.4	127.4	24.5	117.6	23.5	110.8	21.5	102.9
DCN 400H	72.0%	47.0	199.0	45.1	190.2	43.1	181.4	40.2	167.6	37.2	154.9	34.3	145.1	32.3	135.3
DCN 500H	72.0%	93.1	310.8	88.2	297.1	84.3	282.4	78.4	262.8	72.5	243.2	67.6	227.5	63.74	211.8
DCN 550H	72.0%	123.5	374.6	117.6	357.9	111.8	341.2	103.9	316.7	96.1	293.2	90.2	274.5	84.3	255.9
DCN 600H	72.0%	158.8	442.2	151.0	421.6	144.1	402.0	132.3	368.7	119.6	334.4	110.8	307.9	101.0	281.4
DCN 700H	72.0%	251.0	601.1	240.2	573.6	228.4	547.2	212.8	508.9	197.1	470.7	184.3	441.3	172.6	411.8
DCN 800H	72.0%	382.4	799.2	364.8	762.9	347.1	726.6	321.6	673.7	297.1	620.7	276.5	579.5	256.9	537.4
DCN 900H	72.0%	542.3	1008.1	517.7	962.0	493.2	916.9	456.0	848.2	419.7	779.6	390.3	726.6	361.8	672.7
DCN 1000H	72.0%	745.3	1246.4	710.9	1190.5	677.6	1133.6	626.6	1049.3	576.6	964.9	537.4	899.2	498.1	833.5
DCN 1050H	72.0%	862.0	1373.9	822.7	1311.1	783.5	1248.3	725.6	1156.2	667.8	1064.0	621.7	991.4	576.6	918.8
DCN 1100H	72.0%	989.4	1505.3	944.3	1436.6	899.2	1369.0	833.5	1268.0	767.8	1167.9	715.8	1089.5	663.9	1011.0
DCN 1200H	72.0%	1285.6	1793.6	1227.7	1712.2	1168.9	1630.8	1083.6	1511.2	998.3	1391.5	931.6	1298.4	864.9	1205.2
DCN 1300H	72.0%	1636.7	2106.4	1562.2	2010.3	1487.6	1915.2	1376.8	1773.0	1267.0	1630.8	1180.7	1519.0	1094.4	1408.2
DCN 1400H	72.0%	2044.6	2443.8	1952.5	2333.0	1859.3	2222.1	1721.0	2057.4	1582.7	1892.6	1475.9	1764.2	1368.0	1635.7
DCN 1600H	72.0%	3049.8	3190.1	2911.5	3044.9	2773.3	2899.8	2567.3	2685.0	2361.4	2470.3	2201.5	2302.6	2041.7	2134.9
DCN 1800H	72.0%	4349.2	4043.2	4152.1	3859.9	3954.0	3675.5	3660.8	3402.9	3367.6	3131.2	3139.1	2918.4	2910.6	2705.6
DCN 2000H	72.0%	5943.8	4972.9	5674.1	4747.4	5404.4	4521.8	5002.3	4185.4	4600.3	3849.1	4286.4	3586.2	3972.6	3323.4
DCN 2250H	72.0%	8879.9	6637.1	8475.8	6335.1	8072.8	6033.0	7668.8	5731.0	7264.7	5428.9	6860.7	5127.9	6456.7	4825.8
DCN 2500H	72.0%	12181.8	8159.1	11627.7	7788.4	11073.6	7416.7	10519.5	7046.0	9965.5	6675.3	9411.4	6303.7	8857.3	5933.0

Note : Intermediate performance with similar E/R ratio are available in between grades.

(R: REACTION FORCE (KN) , E: ENERGY ABSORPTION (KNM), TOLERANCE ±10%.)

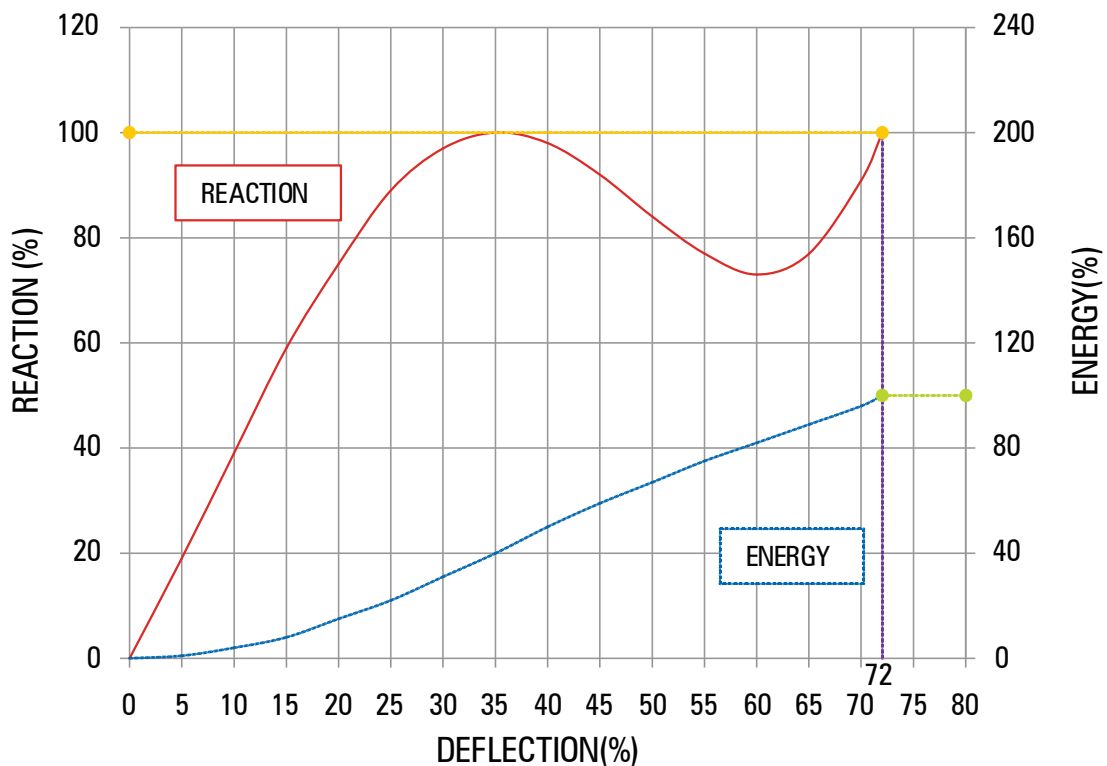

CONE FENDERS - DCN SERIES

PERFORMANCE TABLE

MODEL	DEFLECTION	R2.3		R3		R3.1		R3.2		R3.3		R4	
		E	R	E	R	E	R	E	R	E	R	E	R
DCN 300H	72.0%	12.7	69.6	11.7	62.7	10.7	58.8	9.8	53.9	8.8	50.9	8.8	49.0
DCN 350H	72.0%	19.6	94.1	17.6	86.3	16.6	80.4	15.6	73.5	14.7	70.6	13.7	66.6
DCN 400H	72.0%	29.4	123.5	27.4	112.7	25.5	104.9	23.5	97.0	21.5	92.1	20.5	87.2
DCN 500H	72.0%	57.8	194.1	52.9	176.5	49.0	164.7	45.1	152.0	43.1	144.1	41.1	137.2
DCN 550H	72.0%	77.4	235.3	70.6	213.7	65.7	198.0	59.8	183.3	56.8	173.5	53.9	164.7
DCN 600H	72.0%	93.1	260.8	86.3	240.2	80.4	224.5	75.5	209.8	71.5	199.0	67.6	189.2
DCN 700H	72.0%	159.8	381.4	147.1	352.0	138.2	331.4	130.4	310.8	123.5	295.1	116.7	279.4
DCN 800H	72.0%	237.3	497.2	218.6	456.9	204.9	427.5	190.2	399.1	181.4	378.5	171.6	358.9
DCN 900H	72.0%	336.3	625.6	310.8	577.6	293.2	545.2	275.5	512.8	261.8	487.3	248.1	461.8
DCN 1000H	72.0%	461.8	772.7	425.6	712.9	401.0	671.7	376.5	629.5	357.9	598.2	338.3	566.8
DCN 1050H	72.0%	535.4	853.1	493.2	786.4	464.8	740.4	436.4	694.3	413.8	659.9	392.2	625.6
DCN 1100H	72.0%	615.8	937.5	567.8	863.9	533.4	811.9	500.1	761.0	474.6	722.7	450.1	684.5
DCN 1200H	72.0%	802.1	1117.9	739.4	1030.6	695.2	969.8	651.1	909.0	618.8	862.9	586.4	817.8
DCN 1300H	72.0%	1014.9	1307.2	936.5	1205.2	881.6	1134.6	826.7	1064.0	785.5	1011.0	744.3	958.1
DCN 1400H	72.0%	1269.9	1517.0	1170.9	1399.4	1102.2	1317.0	1032.6	1234.6	981.6	1172.8	929.6	1112.0
DCN 1600H	72.0%	1893.6	1979.9	1745.5	1825.0	1641.6	1716.1	1536.7	1607.3	1460.2	1526.9	1382.7	1446.4
DCN 1800H	72.0%	2699.7	2509.5	2487.9	2313.3	2340.8	2176.1	2192.7	2037.8	2082.9	1936.8	1973.1	1834.8
DCN 2000H	72.0%	3686.3	3084.1	3399.9	2844.9	3199.9	2677.2	3000.1	2510.5	2849.8	2384.9	2699.7	2259.4
DCN 2250H	72.0%	6052.6	4523.8	5648.6	4221.7	5244.6	3919.7	4841.5	3618.6	4437.5	3316.6	4033.4	3014.5
DCN 2500H	72.0%	8303.2	5561.3	7749.2	5190.6	7196.1	4819.9	6642.0	4448.3	6087.9	4077.6	5533.8	3705.9

Note : Intermediate performance with similar E/R ratio are available in between grades.

(R: REACTION FORCE (KN) , E: ENERGY ABSORPTION (KNM), TOLERANCE $\pm 10\%$.)

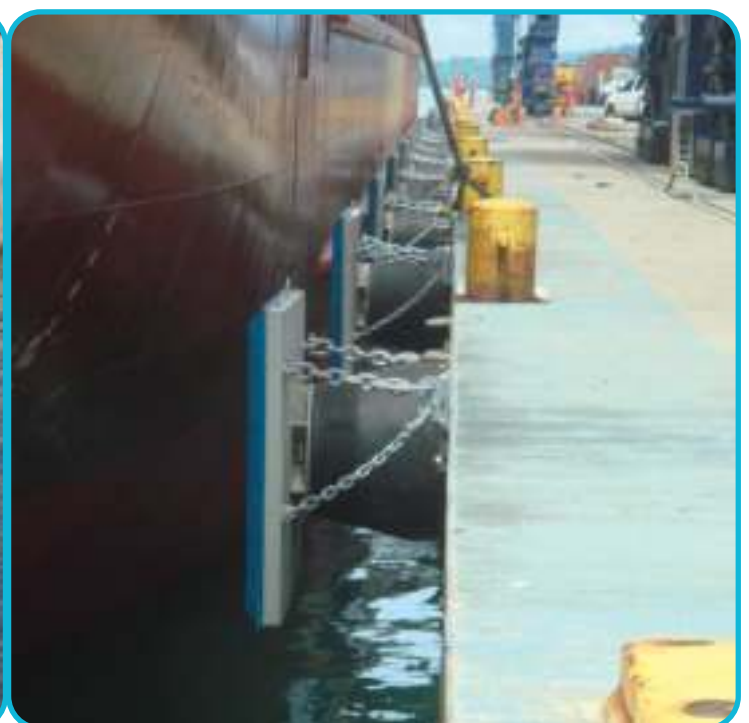

CONE FENDERS - DCN SERIES

CORRECTION FACTORS

ENERGY

Velocity Correction Factor-Energy Absorption	
Berthing Velocity (M/sec)	Correction Factor-Energy Absorption
0.001	0.896
0.050	0.981
0.100	0.992
0.150	1.000
0.200	1.001
0.250	1.004
0.300	1.008

REACTION

Velocity Correction Factor-Reaction Force	
Berthing Velocity (M/sec)	Correction Factor-Reaction Force
0.001	0.904
0.050	0.990
0.100	0.998
0.150	1.000
0.200	1.002
0.250	1.005
0.300	1.009

Temperature Correction Factor-Energy Absorption	
Temperature (Deg C)	Energy Absorption Correction Factor
-30	1.102
-20	1.092
-10	1.037
0	1.011
10	1.006
20	1.003
23	1.000
30	0.936
40	0.963
50	0.952

Temperature Correction Factor-Reaction Force	
Temperature (Deg C)	Reaction Correction Factor
-30	1.093
-20	1.059
-10	1.049
0	1.043
10	1.034
20	1.018
23	1.000
30	0.984
40	0.947
50	0.947

Angular Correction Factor - Energy Absorption	
Berthing Angle(Degree)	Energy Absorption Correction Factor
0	1.000
3	1.062
5	1.047
8	1.022
10	1.011
15	0.981
20	0.933

ROLLER FENDERS

ROLLER FENDERS - DRF SERIES	53-54
ROLLER FENDERS - DR SERIES	55-56

ROLLER FENDERS

Roller Fenders are designed to protect the structures while a vessel is approaching an entrance channel or coming for dry docking.

Roller Fenders are more resistant to wear and tear under their capability to rotate in the direction of the impact.

Roller Fenders are manufactured and assembled using unique technology for a uniform deflection of the rollers and a smooth rotational movement in the direction of the force - thus ensuring a safe passage of the vessels without damaging the structure. The superior moulding technology employed in the high-pressure thermic fluid heated hydraulic presses ensure long life and trouble-free performance.

Roller Fenders are perfectly engineered and assembled in steel fabricated housing, coated with high build epoxy paint to ensure trouble-free operations. If required, various services can be provided for supervising the installation of the roller fenders. All roller fenders come with complete details of all parts/components as well as a Periodic Maintenance and Service Manual which enables the end users to get maximum service life of them.

Key Attributes :

- Extremely robust and absorbs heavy impacts without any damage
- Neutralizes most of the impact energy
- Copes easily with lateral/grazing loading when the vessels move parallel to the wharf
- Low maintenance design
- Low rolling resistance

Range

Roller Fenders are available in wide range from 600mm diameter to 3000mm diameter.

Applications

- Dry-dock entrances and walls
- Lock approaches
- Narrow entries, exits & corners



ROLLER FENDERS - DRF SERIES

DIMENSION TABLE

ALL DIMENSIONS ARE IN MM

MODEL	H	ØD	T	W	BOLT SIZE F	L1	L2	L3
DRF 060-20	620	600	200	695	M22	425	775	1120
DRF 075-25	775	750	250	870	M22	520	950	1365
DRF 090-30	930	900	300	1040	M27	620	1125	1640
DRF 120-40	1240	1200	400	1380	M30	825	1500	2185
DRF 150-50	1550	1500	500	1740	M33	1020	1850	2700
DRF 175-60	1810	1750	650	2010	M39	1250	2260	3310
DRF 180-60	1860	1800	600	2080	M39	1220	2225	3225
DRF 210-70	2205	2100	700	2440	M45	1415	2600	3775
DRF 240-80	2480	2400	800	2770	M48	1600	2975	4295
DRF 270-90	2790	2700	900	3130	M56	1820	3325	4835
DRF 300-100	3100	3000	1000	3480	M64	2020	3690	5370

DRF-1

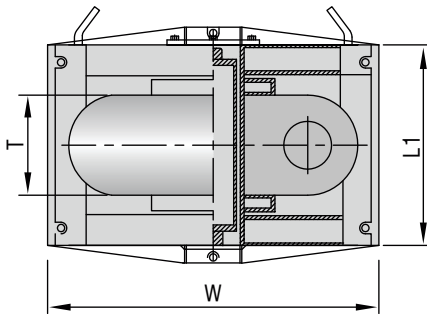

DRF-2

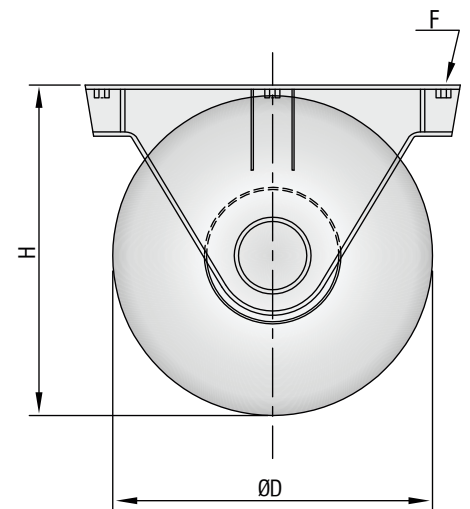
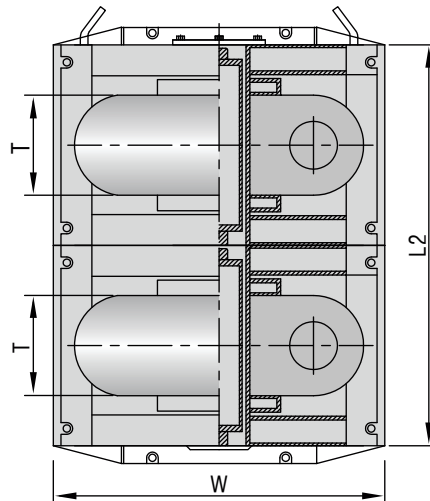

DRF-3

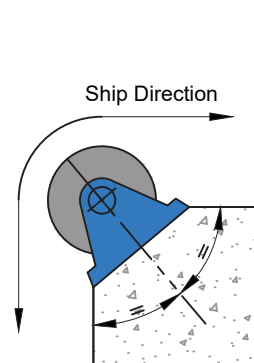
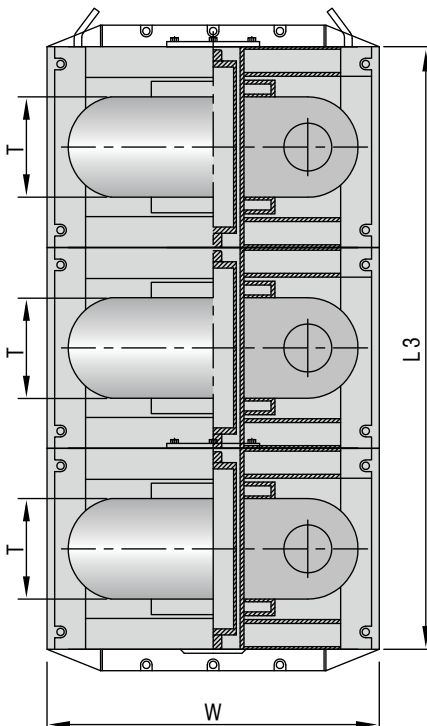

90° corner of jetty

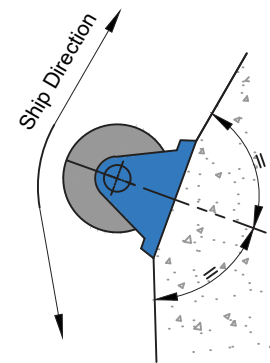

Angled corner jetty

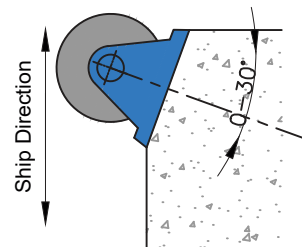

0-30° from main berthing line

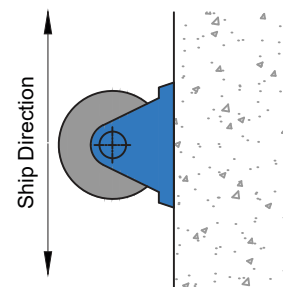

Parallel to ship direction

ROLLER FENDERS - DRF SERIES

PERFORMANCE TABLE

MODEL	DEFLECTION (MM)	DRF 1		DRF 1.1		DRF 2		DRF 2.1		DRF 3		DRF 3.1	
		E	R	E	R	E	R	E	R	E	R	E	R
DRF 060-20	125	2.9	66.6	3.9	100.0	4.9	133.3	5.88	166.7	6.8	200.0	7.8	233.4
DRF 075-25	159	4.9	103.9	6.8	155.9	8.8	208.8	11.77	262.8	14.7	315.7	17.6	369.7
DRF 090-30	185	8.8	152.0	12.7	226.5	15.6	301.0	20.59	377.5	24.5	454.0	29.4	530.5
DRF 120-40	260	18.6	267.7	28.4	404.0	38.2	539.3	48.05	676.6	56.8	813.9	66.6	951.2
DRF 150-50	325	36.2	419.7	56.8	634.4	76.4	848.2	95.12	1058.1	113.7	1268.0	132.3	1477.8
DRF 175-60	368	54.9	509.9	82.3	762.9	109.8	1014.9	138.27	1275.8	165.7	1535.7	194.1	1796.5
DRF 180-60	390	63.7	608.0	98.0	913.0	132.3	1217.0	164.75	1522.9	197.1	1827.9	229.4	2133.9
DRF 210-70	455	105.9	826.7	153.9	1238.5	202.0	1650.4	253.01	2062.3	304.0	2473.2	355.0	2885.1
DRF 240-89	510	143.1	1078.7	212.8	1619.0	281.4	2159.4	349.12	2697.8	416.7	3236.1	484.4	3774.5
DRF 270-96	578	217.7	1368.0	328.5	2047.6	439.3	2726.2	548.19	3408.7	657.0	4091.3	765.9	4773.8
DRF 300-100	640	301.0	1672.0	450.1	2515.4	598.2	3358.7	751.19	4196.2	903.1	5032.7	1056.1	5870.2

Note : Intermediate performance with similar E/R ratio are available in between grades.

(R: REACTION FORCE (KN) , E: ENERGY ABSORPTION (KNM), TOLERANCE $\pm 10\%$)



ROLLER FENDERS - DR SERIES

DIMENSION TABLE

ALL DIMENSIONS ARE IN MM

MODEL	H	ØD	T	W	L1	L2	L3
DR 110-45	1450	1080	460	1700	900	1800	2700
DR 120-40	1560	1200	400	1600	900	1800	2700
DR 130-50	1750	1300	510	2000	1000	2000	3000
DR 150-50	1950	1500	500	2000	1130	2260	3390
DR 175-60	2350	1750	650	2720	1250	2500	3750
DR 175-70	2200	1750	690	2650	1150	2300	3450
DR 180-60	2380	1800	650	2760	1375	2750	4125
DR 200-75	2550	1980	760	2750	1250	2500	3750
DR 210-70	2730	2100	700	2800	1580	3160	4740
DR 240-80	3120	2400	800	3200	1825	3650	5475
DR 250-100	3200	2550	970	3350	1600	3200	4800
DR 270-90	3515	2700	900	3600	2050	4100	6150
DR 290-110	3750	2900	1000	2900	1700	3400	5100
DR 300-100	3900	3000	1000	4000	2275	4550	6825

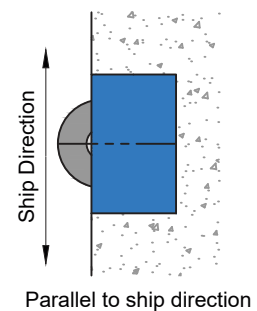
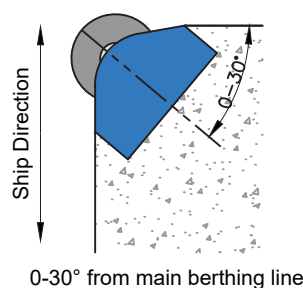
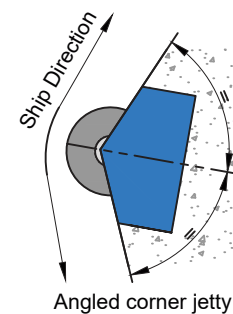
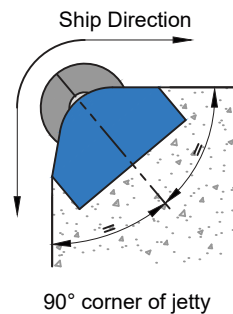
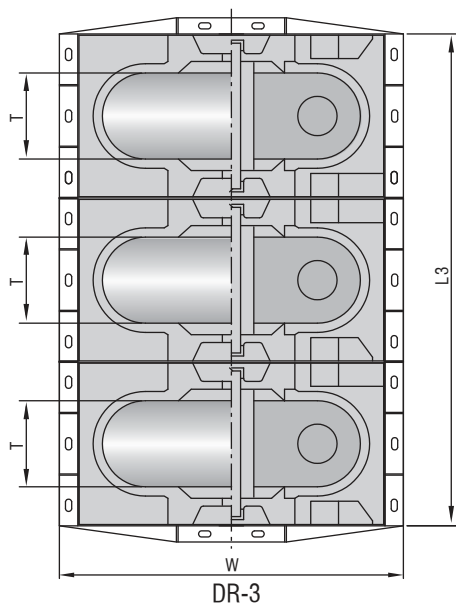
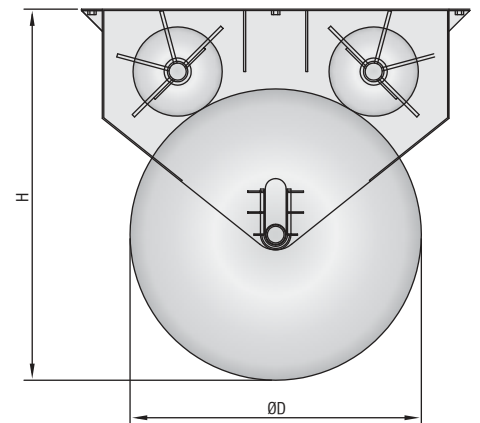
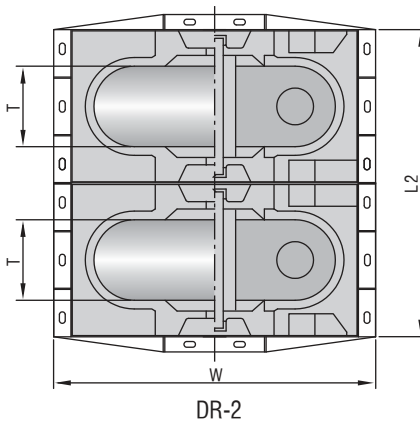
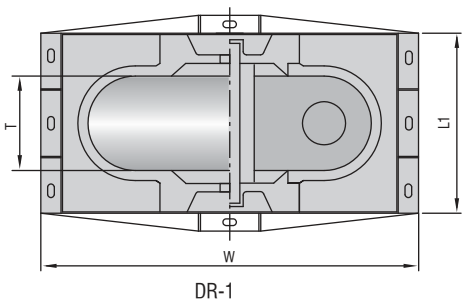

ROLLER FENDERS - DR SERIES

PERFORMANCE TABLE

MODEL	DEFLECTION (MM)	DR 1		DR 1.1		DR 2		DR 2.1		DR 3		DR 3.1	
		E	R	E	R	E	R	E	R	E	R	E	R
DR 110-45	400	27.0	150	44.1	245.0	54.0	300.1	88.2	490.0	81.0	450.1	132.3	735.0
DR 120-40	430	47.6	246.1	71.5	369.7	95.2	492.2	143.1	739.4	142.9	738.3	214.6	1109.1
DR 130-50	500	49.4	219.7	87.8	390.0	98.9	439.3	175.5	780.0	148.3	659.0	263.3	1170.0
DR 150-50	540	93.9	386.3	141.1	580.5	187.7	772.6	282.1	1161.0	281.6	1158.9	423.2	1741.5
DR 175-60	630	132.6	467.7	198.5	700.1	265.2	935.4	397.0	1400.2	397.8	1403.1	595.4	2100.3
DR 175-70	640	135.4	470.0	207.9	722.0	270.7	940.0	415.9	1444.0	406.1	1410.0	623.8	2166.0
DR 180-60	650	162.9	557.0	243.5	832.5	325.8	1114.0	487.0	1665.0	488.8	1671.0	730.5	2497.5
DR 200-75	700	185.7	589.4	306.7	973.5	371.3	1178.8	613.3	1947.0	557.0	1768.1	920.0	2920.5
DR 210-70	760	259.9	760.0	390.1	1140.5	519.8	1520.0	780.1	2281.0	779.8	2280.0	1170.2	3421.5
DR 240-80	850	334.7	875.0	580.3	1517.0	669.4	1750.0	1160.5	3034.0	1004.1	2625.0	1740.8	4551.0
DR 250-100	925	382.9	919.9	686.8	1650.0	765.8	1839.7	1373.6	3300.0	1148.7	2759.6	2060.4	4950.0
DR 270-90	960	542.2	1255.2	813.4	1882.8	1084.5	2510.4	1626.7	3765.6	1626.7	3765.6	2440.1	5648.4
DR 290-110	1200	701.7	1299.4	1424.0	2637.0	1403.3	2598.8	2848.0	5274.0	2105.0	3898.1	4271.9	7911.0
DR 300-100	1200	972.0	1800.0	1458.0	2700.0	1944.0	3600.0	2916.0	5400.0	2916.0	5400.0	4374.0	8100.0

Note : Intermediate performance with similar E/R ratio are available in between grades.

(R: REACTION FORCE (KN) , E: ENERGY ABSORPTION (KNM), TOLERANCE ±10%)



FENDER TESTING

WORLD'S BIGGEST CONE FENDERS



FENDERING SYSTEM DESIGN DATA SHEET

Date: _____

Project Information

Project Name

Berth Type

Client

Consultant

Contractor

Contact

Email

Project Type : New Construction Upgrade

Vessel Information

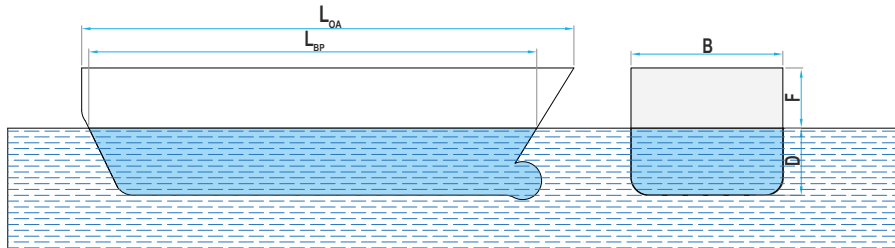

Largest Ships

Type	
Dead Weight	DWT
Displacement	t
Length Overall L_{OA}	m
Length L_{BP}	m
Beam	m
Draft	m
Freeboard	m
Hull Pressure	KN/M ² (KPa)
Belting	<input type="checkbox"/> Yes <input type="checkbox"/> No Size(mm)
Berthing Speed	m/s
Berthing Angle	deg

Smallest Ships

Type	
Dead Weight	DWT
Displacement	t
Length Overall L_{OA}	m
Length L_{BP}	m
Beam	m
Draft	m
Freeboard	m
Hull Pressure	KN/M ² (KPa)
Belting	<input type="checkbox"/> Yes <input type="checkbox"/> No Size(mm)
Berthing Speed	m/s
Berthing Angle	deg

Berth Information

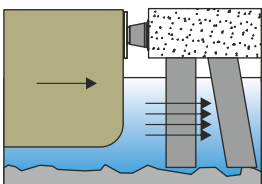

(A) Open Structure

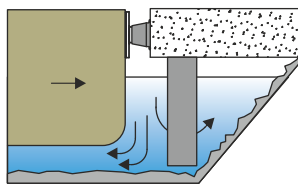

(B) Semi Open

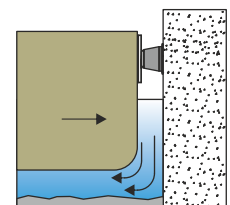

(C) Closed Structure

Structure Type

Open Pile Jetty

Dolphin

Monopile

Mass Structure

Length of berth	m	Fender Spacing	m
Allowable Fender Reaction	(kN or kN/m)	Quay level	m
Seabed level	m	Under keel Clearance	m(mix) m(max)
Specing Requirements	m	Standoff	m(mix) m(max)
Tidal Levels			
Tidal Range	m	HWL	m
LWL	m	MSL	m
Operating temperature	min (°C)	max (°C)	

Berthing Parameters

Berthing Approach (PIANC Standard)

- Good berthing conditions, sheltered
 Difficult berthing conditions, sheltered
 Good berthing conditions, exposed
 Good berthing conditions, exposed
 Navigation conditions difficult, exposed

Berthing Method

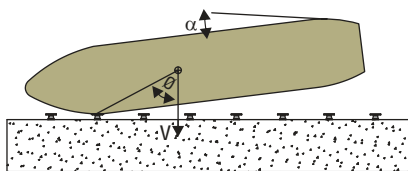

(1) Side Berthing

Berthing Point

- 1/4 Point 1/2 Point
 1/3 Point Others

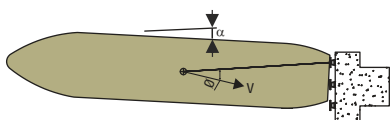

(3) End Berthing

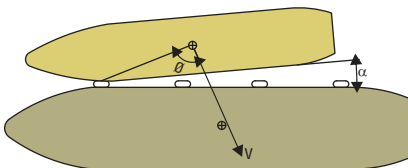

(5) Double Banking of Ship

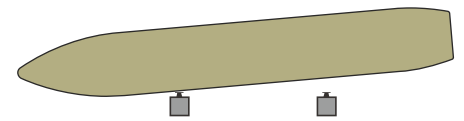

(2) Dolphin Berthing

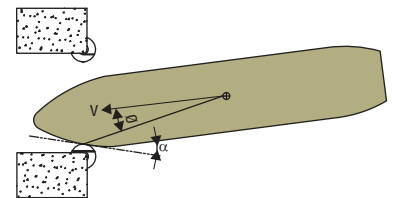

(4) Lock / Dock Entrances

Other Information

TECHNICAL SPECIFICATION OF RUBBER

PROPERTY		UNIT	REQUIREMENT	RELAVANT TESTING STANDARDS AND CONDITIONS
BEFORE AGING	TENSILE STRENGTH	Kg/Cm ²	MIN. 160	(ASTM D412 DIE C/BS 903 A.Z.) JIS K 6301 ITEM 3 DUMBELL NO. 3
	ELONGATION	%	MIN. 350	
	HARDNESS	Deg.	MAX. 77	(ASTM D2240 SHORE A DUROMETER/BS 903 A.Z.) JIS K 6301 ITEM 5 A TYPE TESTER
AFTER AGING	CHANGES IN TENSILE STRENGTH	%	NOT LESS THAN 80% OF ORIGINAL VALUE	AGING THROUGH AIR HEATING (ASTM D573 DIE C/BS 903 A.Z.) JIS K 6301 ITEM 6 DUMBELL NO. 3 70°C X 96 HRS.
	CHANGES IN ELONGATION	%	NOT LESS THAN 80% OF ORIGINAL VALUE	
	HARDNESS	Deg.	ORIGINAL VALUE +8° MAX	(ASTM D2240 SHORE A DUROMETER/BS 903 A.Z.) JIS K 6301 ITEM 5 A TYPE TESTER
TEAR RESISTANCE		Kg/Cm ²	MIN. 70	(ASTM D624 DIE B/BS 903 A.3.) JIS K 6301 ITEM 9 TEST PIECE TYPE A
COMPRESSION SET		%	MAX. 30	70°C X 22 HRS. HEAT TREATMENT (ASTM D395/BS 903 A 6A) JIS K 6301 ITEM 9 TEST PIECE TYPE A
ABRASION RESISTANCE		Cc	MAX. 1.5	BRITISH STANDARD BS903 A9 METHOD-C 3000 REVOLUTIONS
OZONE RESISTANCE			NO CRACKS	ASTM D 1171

All above tests for Rubber compound will be provided in our laboratory or any Reputed Test Laboratories.

CONVERSION TABLE

<p>LENGTH</p> <p>FEET x 0.3048 = METERS</p> <p>INCHES x 25.4 = MILLIMETERS</p> <p>YARDS x 0.914 = METERS</p> <p>MILES x 1.609 = KILOMETERS</p>	<p>METERS x 3.281 = FEET</p> <p>MILLIMETERS x 0.0394 = INCHES</p> <p>METERS x 1.094 = YARDS</p> <p>KILOMETERS x 0.621 = MILES</p>
<p>WEIGHT</p> <p>POUNDS x 0.4536 = KILOGRAMS</p>	<p>KILOGRAMS x 2.205 = POUNDS</p>
<p>AREA</p> <p>SQ. INCHES x 6.5 = SQ. CENTIMETERS</p> <p>SQ. FEET x 0.093 = SQ. METERS</p>	<p>SQ. CENTIMETER x 0.158 = SQ. INCH</p> <p>SQ. METERS x 10.764 = SQ FEET</p>
<p>ENERGY</p> <p>FT. - KIPS. x 0.1383 = TON-M</p>	<p>TON-M x 7.235 = FT. KIPS.</p>
<p>REACTION FORCE</p> <p>KIPS x 0.454 = TONS</p> <p>KILONEWTONS x 0.102 = TONS</p>	<p>KILONEWTONS x 0.102 = TONS</p> <p>TONS x 2.205 = KIPS</p>
<p>SPEED</p> <p>KNOT x 0.515 = METER/SECOND</p>	<p>METER/SECOND x 1.94 = KNOT</p>
<p>MISCELLANEOUS</p> <p>(F'-32) x 5/9 = C*</p> <p>BARREL x 0.11924 = KILOLITER</p> <p>Lb/IN x 0.179 = KG/CM</p> <p>Lb/IN² (PSI) x 0.07 = KG/SQ CM</p> <p>Lb./FT x 4.489 = KG/M</p> <p>Lb/FT³ x 0.016 = G/CU CM</p> <p>KIPS/FT² x 4.878 = TON/SQ M</p> <p>KIPS/FT x 1.489 = TON/M</p> <p>NEWTON x 0.102 = KG</p> <p>PASCAL = NEWTON/SQ M</p>	<p>C' x 9/5 + 32 = P</p> <p>KILOLITER x 8.39 = BARREL</p> <p>KG/CM x 5.6 = Lb/IN</p> <p>KG/CM² x 14.22 = Lb/IN² (PSI)</p> <p>KG/M x 0.672 = Lb/FT</p> <p>G/CM³ x 62.5 = Lb/CU FT</p> <p>TON/M² x 0.205 = KIPS/SQ FT</p> <p>TON/M x 0.672 = KIPS/FT</p>

PHOTO GALLERY

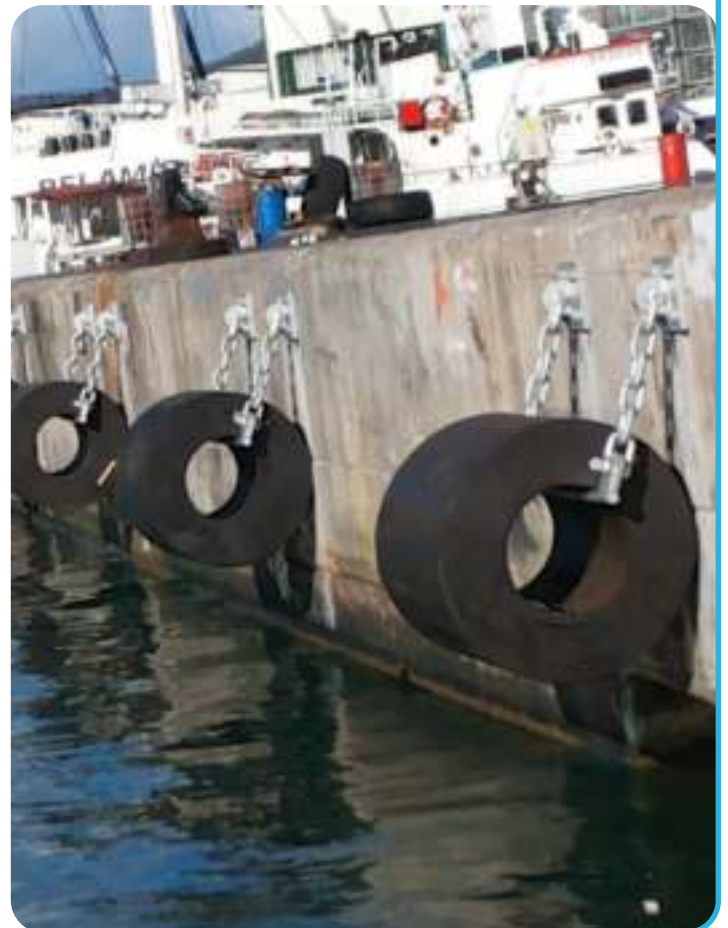
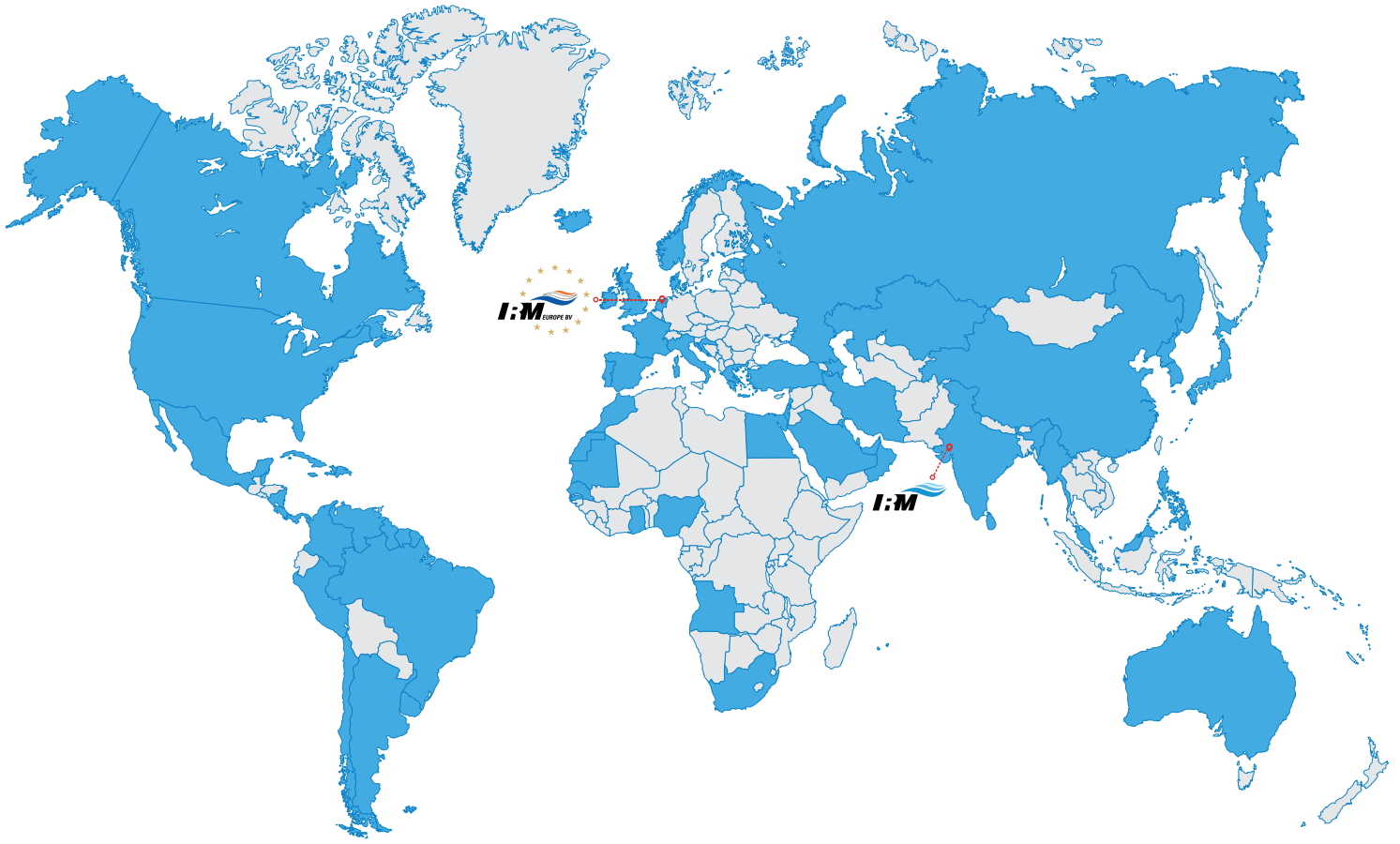

PHOTO GALLERY



IRM PRODUCTS WORLD WIDE



www.irmome.com

Block No. 707, Nandoli Road, Rancharda, Via Thaltej - Shilaj,
Ahmedabad - 382 115, Gujarat - India

M : +91 9825 067611 / +91 9727 738407

E : sales@irmome.com | marketing@irmome.com







www.irmeurope.com

Concordiastraat 84, 1951 AS Velsen-Noord, The Netherlands

M : +31 6268 93082 / +39 3355 648598

E : sales@irmeurope.com | marketing@irmeurope.com

Connect with us:

-  [irmome](#)
-  [irmome](#)
-  [irm-offshore-marine-engineers](#)
-  [IRM Offshore and Marine Engineers IRMOME](#)



Total Solutions to Protect Your Structures