



DOCK ACCESSORIES



IRM DOCK ACCESSORIES

Our quest for customer satisfaction & convenience has prompted us to go for a full fledged horizontal integration and the result was IRM Dock Accessories. As a pioneer in supply of Fendering Systems, we were preferred as a source for all allied accessories and fixtures like CS / CI Bollards, MS / SS and Rubber Ladders, Fender Fixing Hardware, Mooring-Rings, Open and Stud Link Chains, U-Hooks, fabricated Chain Brackets, D-Shackles, Adjustable Shackles, Flex Drum Assemblies (Rubber Flex Chains) and UHMW Facia Pads / Dock Liners etc. We can virtually cater to all the requirements to complement our Marine Fenders. While not exhaustive this catalogue generally covers the range of IRM Dock Accessories manufactured by IRM.

CONTENTS.

Introduction	1
Bollards	3
Material Specification, Painting, Torque Chart	4
Standard Grades of Grey Iron	5
Standard Grades of Ductile Iron/SG Iron	6
Standard Grades of Cast Steel	7
Fixtures	8
Ladders	10
Mooring Rings	11
U Hooks	12
Studless Chain	13
Studlink Chain	14
Tensioner - Type - 1	16
Tensioner - Type - 2	17
Chain Brackets	18
Bow Shackle	19
D Shackle With Nut - Bolt	20
Screw Pin D Shackle	21
Flex Drum Assembly A Series	22
Flex Drum Assembly B Series	23
Anchor Bolt Sleeve Type	24
Anchor Bolt Stud Type	25
Resin Anchor Bolts	26
Frame Fixing Bolt	27
UHMW Facia Pads	28
Technical Specification UHMW PE Pad	29
Edge Protector	30

BOLLARDS

Mooring Bollards are manufactured in different shapes and sizes ranging from capacity 2 Tons to 500 Tons.

Types of Bollards:



STAGHORN BOLLARD



TEE HEAD BOLLARD



KIDNEY BOLLARD



TRICON BOLLARD



CLEAT BOLLARD



BITT BOLLARD

MATERIAL SPECIFICATION

The Bollards are typically manufactured either from Cast Steel and Cast iron. Cast iron usually refers to Gray Iron, Ductile Iron /SG Iron, and Malleable Iron having more than 2% carbon content. Cast steel usually refers to standard carbon steel or alloy steel having maximum carbon content lower than 2%. The material of the Bollard is generally the preference of the client. Both the material have their pros and cons. However, for Bollard, both the material Cast iron and Cast Steel are suitable.

General Characteristics of Ductile Iron/SG Iron:

1. Available in a wide range of mechanical/physical properties.
2. Many iron castings can be used without heat treatment.
3. Excellent damping capacity, especially in Gray Irons.
4. Reduced tendency toward residual stresses.
5. Having better corrosion resistance, wear resistance compared to Cast Steel.
6. Cast iron typically has better compressive strength.

General Characteristics of Cast Steel:

1. Better mechanical strength than Cast Iron.
2. Lower castability than Cast Iron.
3. Wear resistance is less in comparison to Cast Iron.
4. Higher shock resistance than cast iron.
5. Lower corrosion resistance compared to Cast Iron.
6. Heat Treatment is generally required.

PAINTING

Bollards are painted as per ISO 12944 standards. Painting is more significant for Cast Steel Bollards which has less corrosion resistance than Cast Iron Bollards. The Bollards can be painted in any shades as per client's requirement. Generally the Bollards are painted with black or yellow color with high build epoxy paint. During mooring the paint is susceptible to wear, due to the high abrasion forces of the mooring ropes. Hence it is advisable that the coating should be re applied at site by the client as and when required for proper maintenance of Bollards.

PROCEDURE

- The Bollards is sand blasted as per SA 2.5
- Primer: 50 to 60 microns.
- Two Coats of High Build Epoxy Paint: 325 microns.
- Total DFT 375 microns. approx.

TORQUE CHART

SR. NO.	BOLT	TORQUE N.M.
1	M 24	407-441
2	M 27	441-475
3	M 30	475-508
4	M 36	542-610
5	M 42	610-678
6	M 48	746-813
7	M 56	813-881
8	M 64	881-949

STANDARD GRADES OF GREY IRON

Country	Standard	EQUIVALENT GRADES OF GREY IRON (GREY CAST IRON)						
ISO	ISO 185	100	150	200	250	300	350	—
China	GB 9439	HT100	HT150	HT200	HT250	HT300	HT350	—
USA	ASTM A48	—	NO.20 NO.25	NO.30	NO.35	NO.40 NO.45	NO.50	NO.55 NO.60
Germany Austria	DIN 1691	GG10	GG15	GG20	GG25	GG30	GG35	GG40
European	EN 1561	EN-GJL-100	EN-GJL-150	EN-GJL-200	EN-GJL-250	EN-GJL-300	EN-GJL-350	—
Japan	JIS G5501	FC100	FC150	FC200	FC250	FC300	FC350	—
Italy	UNI 5007	G10	G15	G20	G25	G30	G35	—
France	NF A32-101	—	FGL150	FGL200	FGL250	FGL300	FGL350	FGL400
UK	BS 1452	100	150	200	250	300	350	—
India	IS 210	—	FG150	FG200	FG260	FG300	FG350	FG400
Spain	UNF	—	FG15	FG20	FG25	FG30	FG35	—
Belgium	NBN 830-01	FGG10	FGG15	FGG20	FGG25	FGG30	FGG35	FGG40
Australia	AS 1830	—	T150	T220	T260	T300	T350	T400
Sweden	SS 14 01	O110	O115	O120	O125	O130	O135	O140
Norway	NS11 100	SJG100	SJG150	SJG200	SJG250	SJG300	SJG350	—

STANDARD GRADES OF DUCTILE IRON / SG IRON

Country	Standard	EQUIVALENT GRADES OF DUCTILE IRON (SG IRON, NODULAR GRAPHITE IRON)						
ISO	ISO 1083	400-15 400-18	450-10	500-7	600-3	700-2	800-2	900-2
China	GB1348	QT400-18	QT450-10	QT500-7	QT600-3	QT700-2	QT800-2	QT900-2
USA	ASTM A536	60-40-18	60-42-10 65-45-12	70-50-05	80-55-06 80-60-03	100-70-03	120-90-02	—
Germany Austria	DIN 1693	GGG40	—	GGG50	GGG60	GGG70	GGG80	—
European	EN 1563	EN-GJS-400-15 EN-GJS-400-18	EN-GJS-450-10	EN-GJS-500-7	EN-GJS-600-3	EN-GJS-700-2	EN-GJS-800-2	EN-GJS-900-2
Japan	JIS G5502	FCD400	FCD450	FCD500	FCD600	FCD700	FCD800	—
Italy	UNI 4544	GS370-17	GS400-12	GS500-7	GS600-2	GS700-2	GS800-2	—
France	NF A32-201	FGS370-17	FGS400-12	FGS500-7	FGS600-2	FGS700-2	FGS800-2	—
UK	BS 2789	400/17	420/12	500/7	600/7	700/2	800/2	900/2
India	IS 1865	SG370/17	SG400/12	SG500/7	SG600/3	SG700/2	SG800/2	—
Spain	UNF	FGE38-17	FGE42-12	FGE50-7	FGE60-2	FGE70-2	FGE80-2	—
Belgium	NBN 830-02	FNG38-17	FNG42-12	FNG50-7	FNG60-2	FNG70-2	FNG80-2	—
Australia	AS 1831	300-17 400-12	—	500-7	600-3	700-2	800-2	—
Sweden	SS 14 07	0717-02	—	0727-02	0732-03	0737-01	0864-03	—
Norway	NS11 301	SJK-400.3 SJK-400	—	SJK-500	SJK-600	SJK-700	SJK-800	—

STANDARD GRADES OF CAST STEEL

ISO SPECIFICATIONS:

Grade	Tensile Strength, Min. ksi [Mpa]	Yield Strength, Min. ksi [Mpa]	Elongation, Min. %	Reduction of Area, Min. %
3755 Gr. 230-450	65 [450]	33 [230]	22	31
3755 Gr. 270-480	70 [480]	39 [270]	18	25
3755 Gr. 340-550	80 [550]	49 [340]	15	21

ASTM SPECIFICATIONS:

Grade	Tensile Strength, Min. ksi [Mpa]	Yield Strength, Min. ksi [Mpa]	Elongation in 2 in. or 50mm, Min %	Reduction of Area, Min. %
A27 Gr. 65-35	65 [450]	35 [240]	24	35
A27 Gr. 70-36	70 [485]	36 [250]	22	30
A27 Gr. 70-40	70 [485]	40 [275]	22	30
A148 Gr. 80-50	80 [550]	50 [345]	22	35

IS 1030:1998 SPECIFICATIONS:

Grade	Tensile Strength, Min. [Mpa]	Yield Strength Min. [MPa]	Elongation Min. %	Reduction of Area Min. %	Impact Strength J [Min]	Angle of Bend Degrees
200-400N	400	200	25	40	30	90
200-400W	400	200	25	40	45	90
230-450N	450	230	22	31	25	90
230-450W	450	230	22	31	45	90
280-520N	520	280	18	25	22	60
280-520W	520	280	18	25	22	60
340-570N	570	340	15	21	20	60
340-570W	570	340	15	21	20	60

FIXTURES

Bollards are usually supplied with anchor bolts. The anchor bolts are designed for pulling the capacity of the Bollard. An anchor bolt is generally a partial threaded rod having welded anchor plate at the other end, which is embedded into the concrete.

The anchor bolts are of 2 types: 1. Fuse type anchors 2. Standard anchors

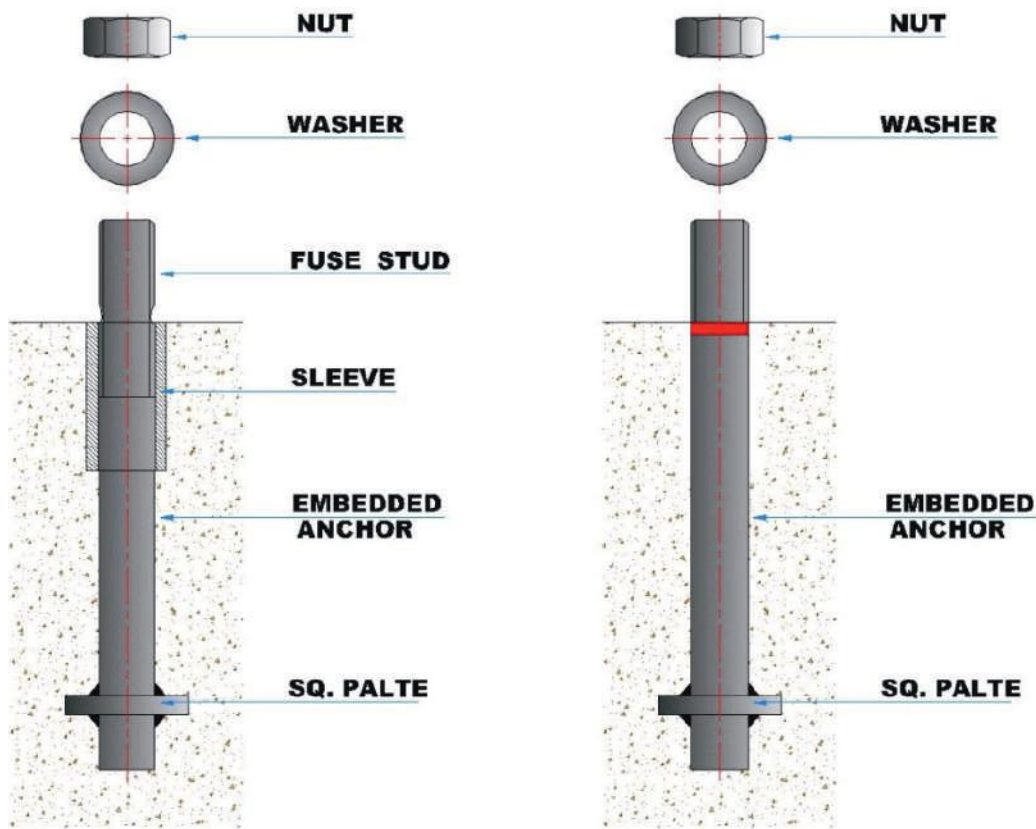

Fuse type anchors

Standard Anchors

All carbon steel anchors and associated nuts and plate washers are supplied hot dip galvanized to ASTM A123 or A153 standards as required.

ITEM	STANDARD GRADES	ISO GRADES
Bolts	ASTM F1554 Gr. 105	ISO 898 Gr. 8.8
Nuts (Heavy Hex)	ASTM A563 Gr. DH	ISO 898 Gr. 8
Washers	ASTM F436	ISO 887
Plate Washers	ASTM A36	ISO 630

PHOTO GALLERY



LADDERS

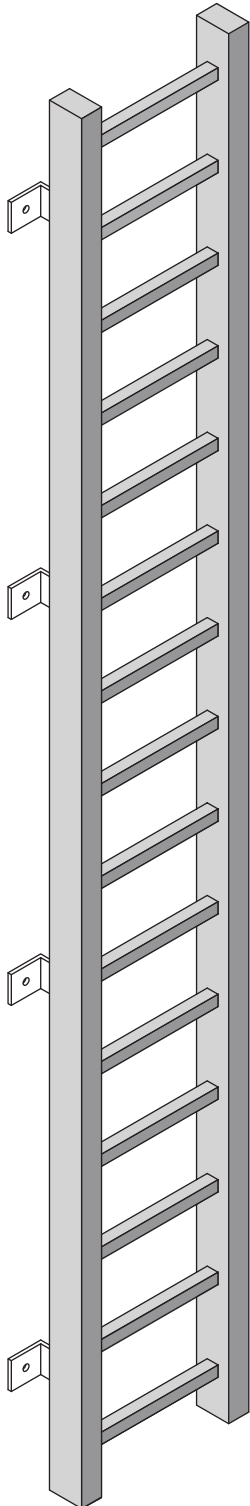

RUBBER LADDER

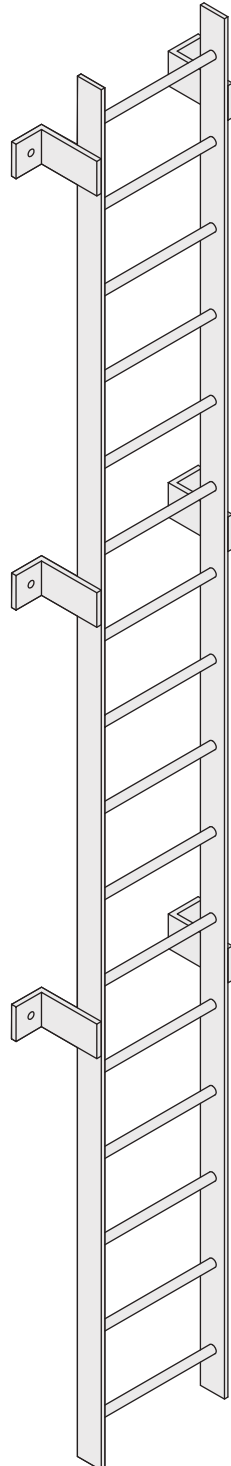

S. S. LADDER

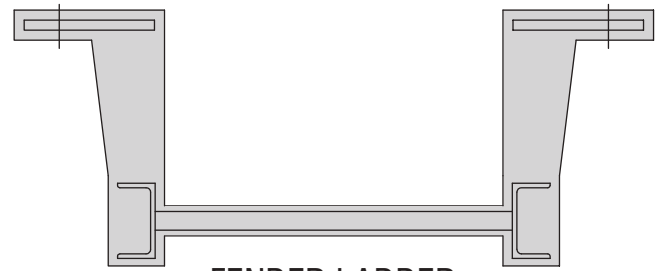

FENDER LADDER



FENDER LADDER

Ladders are available both in Stainless Steel / Moulded Rubber as per the customer's requirement. Unique dual application Fender Ladders are also available, which can be used as Fender for small boats and as Ladder. We offer different types of Ladders from 2-meter length to 10 / 12 Meter length as per the customer's requirement. Dimensional drawings and specifications can be provided on request.

AVAILABLE IN DIFFERENT MATERIAL, CONFIGURATION AND LENGTH

MOORING RINGS

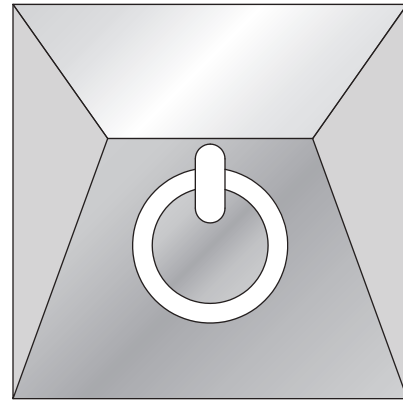
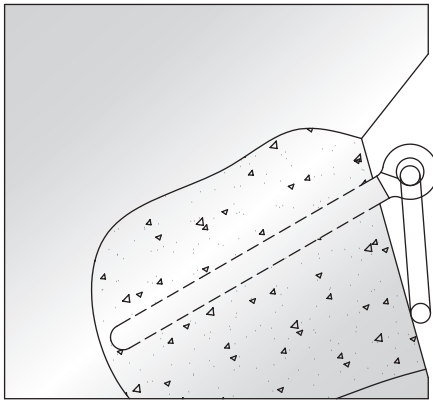
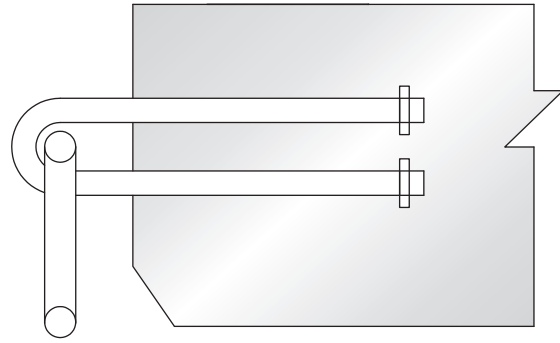
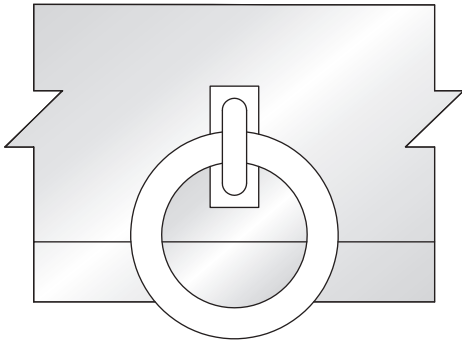

Mooring Rings are available both in MS and SS in different grades. These Rings are used for manoeuvring or fastening small Boats and Crafts. Mooring Rings are available from 12 mm diameter to 100 mm diameter as per requirement.

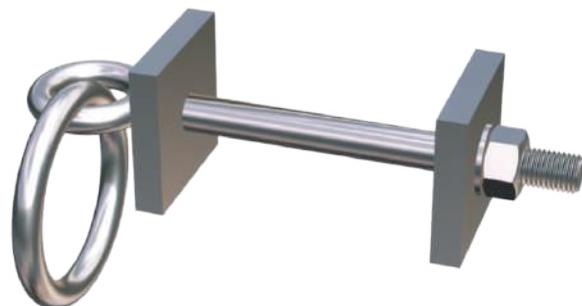

U HOOKS

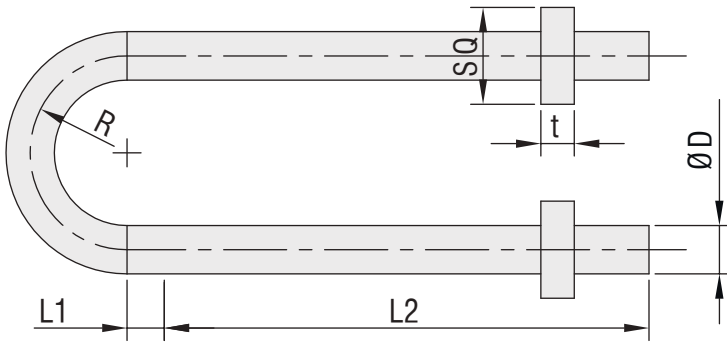

Hooks are available in both MS and SS grades. These hooks are required for fixing Chains for Fendering Systems. U Hooks are available from 10 mm diameter to 100 mm diameter. These Hooks can also be used as an anchor for Mooring Rings.

ALL DIMENSIONS ARE IN MM.

ØD	R	L1	L2	SQ	t	Total Weight
13	26	10	130	26	9	0.42
16	32	11	160	32	9	0.76
19	38	13	190	38	12	1.28
22	44	17	220	44	12	1.94
25	50	18	250	50	16	2.93
28	56	18	280	56	16	4.05
30	60	18	300	60	16	4.94
32	64	18	320	64	16	5.96
34	68	23	340	68	19	7.26
36	72	25	360	72	19	8.39
38	76	27	380	76	19	10.08
40	80	27	400	80	22	11.81
42	84	31	420	84	22	13.68
44	88	33	440	88	22	15.69
46	92	33	460	92	25	17.99
48	96	34	480	96	25	20.37
50	100	36	500	100	25	22.97
55	110	37	550	110	32	30.82
60	120	38	600	120	32	39.65
65	130	42	650	130	36	50.59
70	140	42	700	140	36	62.65
75	150	51	750	150	40	77.68
80	160	55	800	160	40	93.89
85	170	55	850	170	45	112.76
90	180	58	900	180	45	133.29
95	190	58	950	190	50	156.98
100	200	58	1000	200	55	183.31
100	210	58	1100	210	55	203.17

AVAILABLE IN DIFFERENT GRADES BOTH IN SS/MS/ALLOY STEEL.

DIMENSION AND WEIGHT MENTIONED ARE SUBJECT TO CHANGE WITHOUT NOTICE.

STUDLESS CHAIN

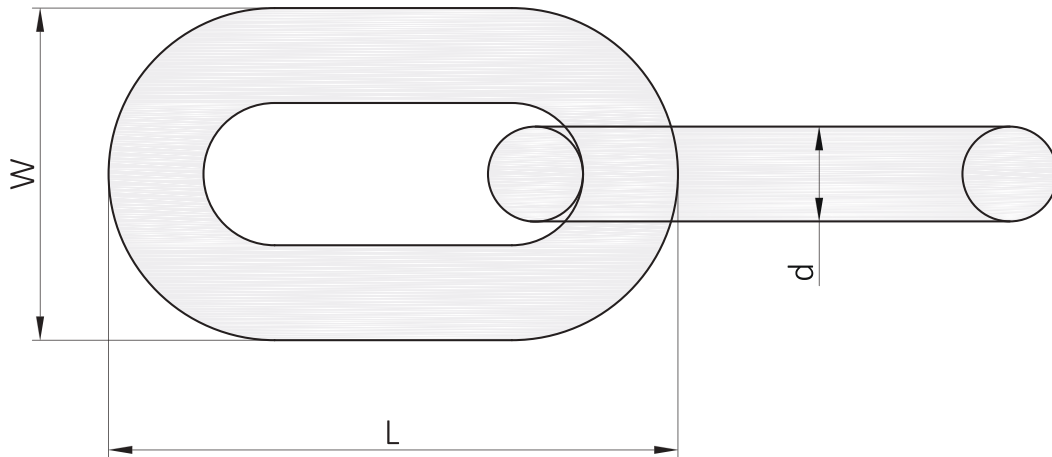

Chain Diameter (MM) d	L	W	Grade 1: BM1, U1a		Grade 2: BM2, U2a		Grade 3: BM3, U3a		Approx Wt of per Mtr. Length
	mm	mm	Proof Load (in KN)	Break load (in KN)	Proof Load (in KN)	Break load (in KN)	Proof Load (in KN)	Break load (in KN)	Kg
12.5	75	44	28.7	57.8	41.2	82.6	56.4	112.8	3.4
14	84	49	34.7	69.9	51.0	101.9	70.7	141.5	3.9
16	96	56	47.1	94.7	66.2	132.3	92.4	184.8	5.0
17.5	105	61	56.3	113.3	78.8	157.7	110.5	221.1	6.4
19	114	67	66.4	133.5	93.6	187.2	130.3	260.6	7.1
20.5	123	72	77.3	155.4	108.6	217.2	151.7	303.4	8.7
22	132	77	89.0	179.0	125.4	250.9	174.4	349.4	9.5
24	144	84	105.9	213.2	149.9	298.9	207.9	415.8	12.5
26	156	91	124.3	250.1	175.4	350.8	244	488	13.3
28	168	98	144.2	290.0	203.8	406.7	283	566	15.4
30	180	105	165.6	333	234.2	467.5	324.9	649.8	17.7
32	192	112	188.4	378.8	265.6	531.2	369.6	739.3	20.2
34	204	119	212.7	427.7	299.9	599.8	417.3	834.6	22.8
36	216	126	238.4	479.5	336.1	672.3	467.8	935.7	25.5
38	228	133	265.7	534.2	374.4	748.7	521.3	1042.5	28.4
40	240	140	294.4	592	414.5	829.1	577.6	1155.2	31.3
42	252	147	324.5	652.6	457.7	915.3	636.8	1273.6	34.6
44	264	154	356.2	716.3	502.7	999.6	698.9	1398	40.3
46	276	161	389.3	782.9	548.8	1097.6	763.9	1527.8	41.5
48	288	168	423.9	852.4	597.8	1195.6	831.7	1663.5	45.3
50	300	175	460	926.0	648.8	1293.6	902.5	1805	49.0
52	312	182	497.5	1000.4	697.6	1395.2	976.1	1952.2	53.6
54	324	189	536.5	1078.9	752.3	1504.6	1052.6	2105.3	60.1
56	336	196	577.0	1160.3	809.0	1618.1	1132.1	2264.2	61.9
58	348	203	618.9	1244.6	867.9	1735.8	1214.4	2428.8	66.5
60	360	210	662.4	1332	928.8	1857.6	1299.6	2599.2	70.2
62	372	217	707.3	1422.2	991.2	1983.5	1387.6	2775.3	75.7
64	384	224	753.6	1515.5	1056.7	2113.5	1478.6	2957.3	84.1
66	396	231	801.5	1611.7	1123.8	2247.7	1572.5	3145.0	86.4
68	408	238	850.8	1710.8	1192.9	2385.9	1669.2	3338.5	90.9
70	420	252					2580	3690	109.5

DIMENSION AND WEIGHT MENTIONED ARE SUBJECT TO CHANGE WITHOUT NOTICE.

STUD LINK CHAIN

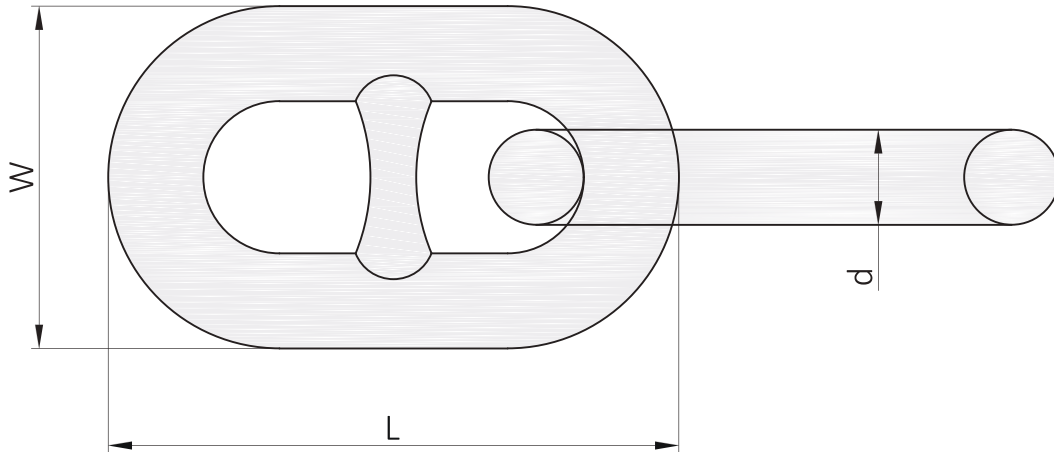

Chain Diameter (MM) d	Proofload			Breakload			Approximate Weight (KG) per Mtr. Length
	Grade 1 (KN)	Grade 2 (KN)	Grade 3 (KN)	Grade 1 (KN)	Grade 2 (KN)	Grade 3 (KN)	
12.5	46	66	92	66	92	132	--
14	58	82	116	82	116	165	--
16	76	107	150	107	150	216	5.8
17.5	89	127	179	127	179	256	6.9
19	105	150	211	150	211	301	8.2
20.5	123	175	244	175	244	349	9.6
22	140	200	280	200	280	401	10.9
24	167	237	332	237	332	476	13.1
26	194	278	389	278	389	556	15.3
28	225	321	449	321	449	642	17.8
30	257	368	514	368	514	735	20.5
32	291	417	583	417	583	833	23.1
34	328	468	655	468	655	937	26.2
36	366	523	732	523	732	1050	29.1
38	406	581	812	581	812	1160	32.5
40	448	640	896	640	896	1280	36.2
42	492	703	981	703	981	1400	40.0
44	538	769	1080	769	1080	1540	43.6
46	585	837	1170	837	1170	1680	48.0
48	635	908	1280	908	1270	1810	52.4
50	686	981	1370	981	1370	1960	56.7
52	739	1060	1480	1060	1480	2110	60.9
54	794	1140	1590	1140	1590	2270	66.2
56	851	1220	1710	1220	1710	2430	70.4
58	909	1290	1810	1290	1810	2600	75.5
60	969	1380	1940	1380	1940	2770	80.7
62	1030	1470	2060	1470	2060	2940	86.0
64	1100	1560	2190	1560	2190	3130	92.7
66	1160	1660	2310	1660	2310	3300	98.0
68	1230	1750	2450	1750	2450	3500	105.1

DIMENSION AND WEIGHT MENTIONED ARE SUBJECT TO CHANGE WITHOUT NOTICE.

STUD LINK CHAIN

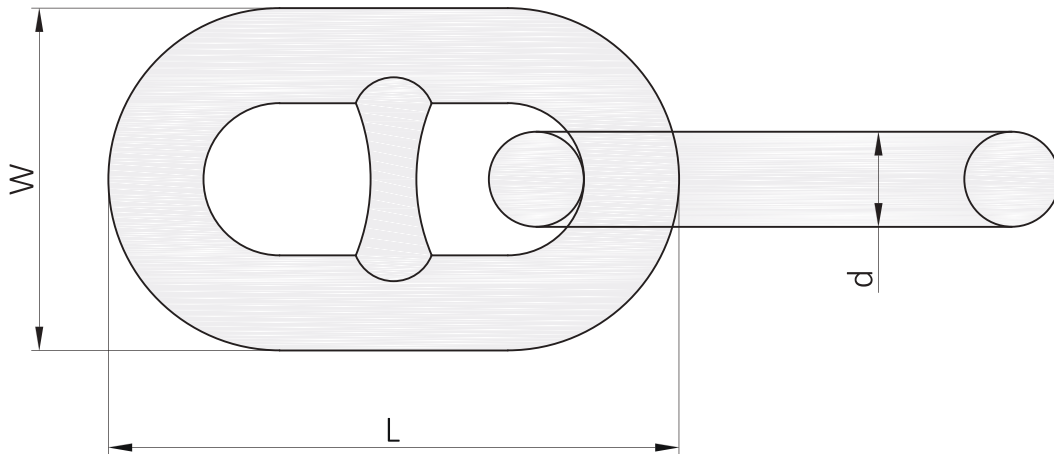

Chain Diameter (MM) d	Proofload			Breakload			Approximate Weight (KG) per Mtr. Length
	Grade 1 (KN)	Grade 2 (KN)	Grade 3 (KN)	Grade 1 (KN)	Grade 2 (KN)	Grade 3 (KN)	
70	1290	1840	2580	1840	2580	3690	110.2
73	1390	1990	2790	1990	2790	3990	119.6
76	1500	2150	3010	2150	3010	4300	129.1
78	1580	2260	3160	2260	3160	4500	136.5
81	1690	2410	3380	2410	3380	4820	146.7
84	1810	2580	3610	2580	3610	5160	159.8
87	1920	2750	3850	2750	3850	5500	173.1
90	2050	2920	4090	2920	4090	5840	182.0
92	2130	3040	5260	3040	4260	6080	189.1
95	2260	3230	4510	3230	4510	6440	202.5
97	2340	3340	4680	3350	4680	6690	209.5
100	2470	3530	4940	3530	4940	7060	222.9
102	2560	3660	5120	3660	5120	7320	236.5
105	2700	3850	5390	3860	5390	7700	250.4
107	2790	3980	5570	3980	5570	7690	259.6
111	2970	4250	5940	4250	5940	8480	280.5
114	3110	4440	6230	4440	6230	8890	294.0
117	3260	4650	6510	4650	6510	9300	307.1
120	3400	4860	6810	4860	6810	9720	331.3
122	3500	5000	7000	5000	7000	9990	336.0
124	3600	5140	7200	5140	7200	10280	352.7
127	3750	5350	7490	5350	7490	10710	365.1
130	3900	5570	7800	5570	7800	11140	378.9
132	4000	5720	8000	5720	8000	11420	396.7
137	4620	6080	8510	6080	8510	12160	426.2
142	4520	6450	9030	6450	9030	12910	455.1
147	4790	6840	9560	6840	9560	13660	483.5
152	5050	7220	10100	7220	10100	14430	534.4
157	5320	7600	10640	7600	10640	15200	562.7
162	5590	7990	11180	7990	11180	15980	589.5

DIMENSION AND WEIGHT MENTIONED ARE SUBJECT TO CHANGE WITHOUT NOTICE.

TENSIONER - TYPE - 1

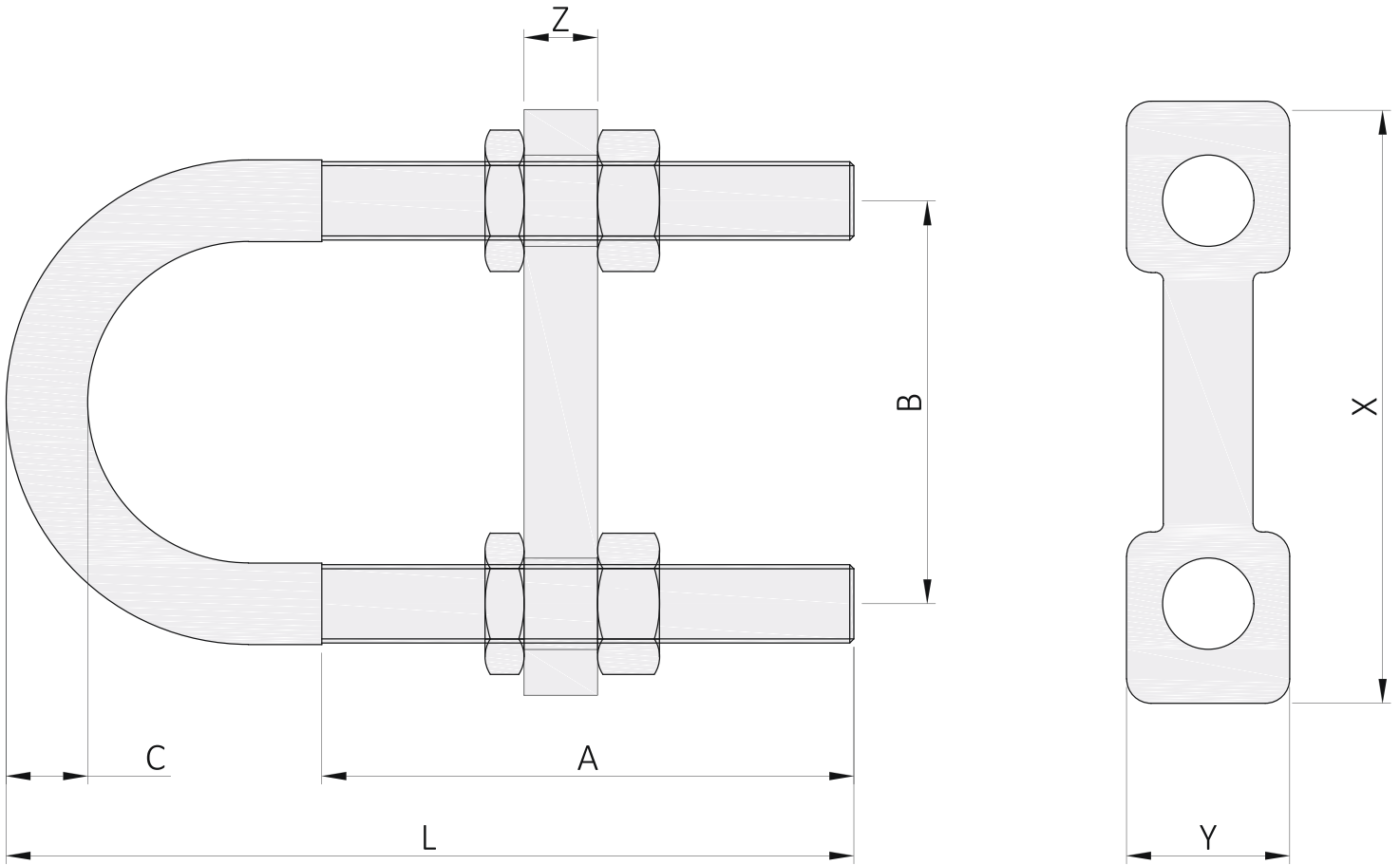

Size	L	A	B	C	X	Y	Z	Approximate Weight (Kg)
M16	300	235	84	18	140	45	20	2.4
M20	330	245	101	22	165	48	25	3.8
M27	375	275	130	28	190	60	28	7.0
M30	400	300	170	32	260	75	36	12.1
M36	425	300	166	36	260	75	36	14.2
M39	460	305	209	40	310	100	40	21.5
M42	485	310	202	45	315	100	45	26.5
M48	520	325	247	50	370	100	50	35.6
M56	600	380	270	60	405	115	55	52.4

NOTE : THE ABOVE DIMENSIONS MAY VARY ON CASE TO CASE BASIS.

ALL DIMENSIONS ARE IN MM

TENSIONER - TYPE - 2

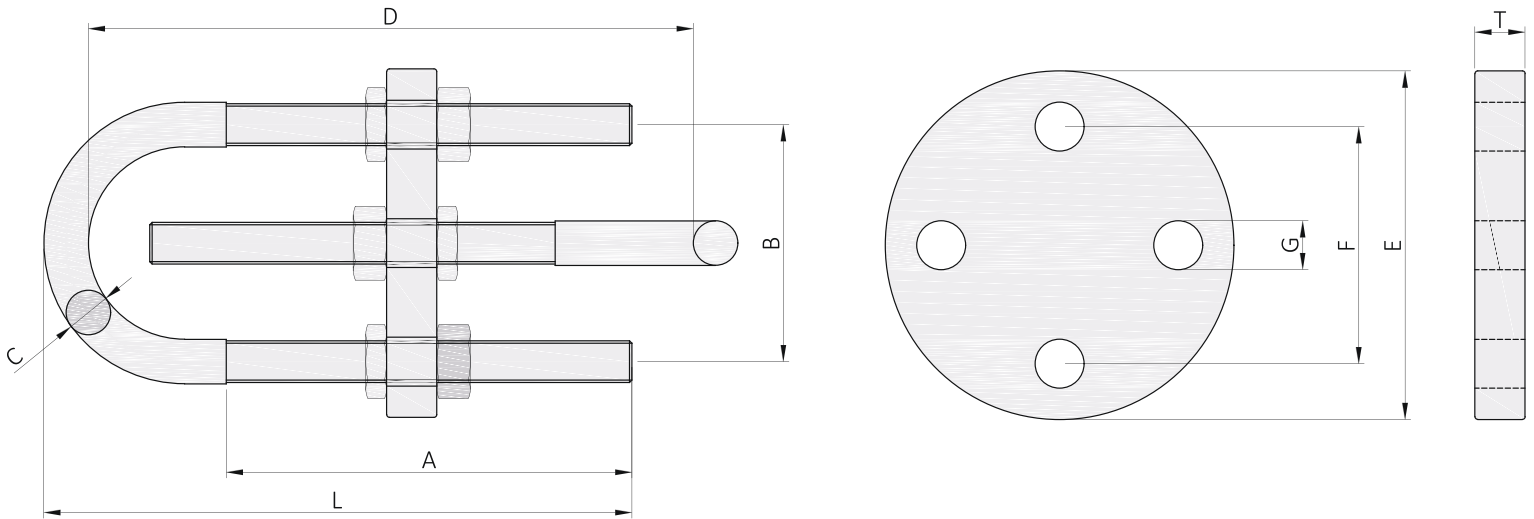

Size	L	A	B	C	D	E	F	G	T	Approximate Weight (Kg)
M20	290	210	101	22	215-450	155	101	24	25	8.3
M27	325	225	130	28	235-475	200	130	32	28	16.0
M30	365	235	170	32	305-545	250	170	36	32	25.8
M36	375	245	166	36	305-545	250	166	42	36	32.7
M39	410	255	209	40	375-615	300	209	45	40	47.5
M42	430	255	202	45	380-615	300	202	48	45	57.8
M48	465	275	247	50	455-690	370	247	56	50	88.6
M56	600	380	270	60	510-930	400	270	62	55	125.6

NOTE : THE ABOVE DIMENSIONS MAY VARY ON CASE TO CASE BASIS.

ALL DIMENSIONS ARE IN MM

CHAIN BRACKETS

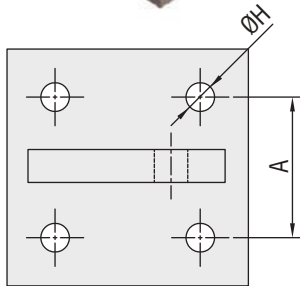
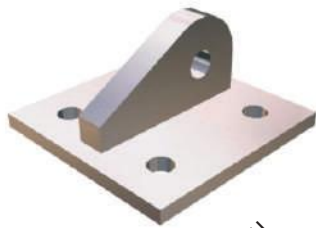

DCB-A

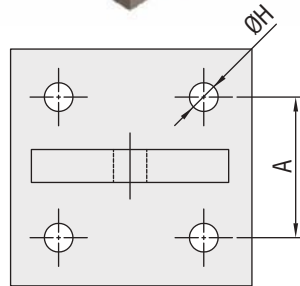
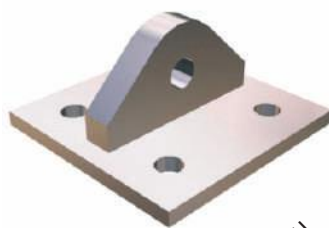

DCB-B

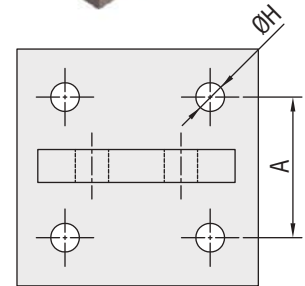

DCB-C

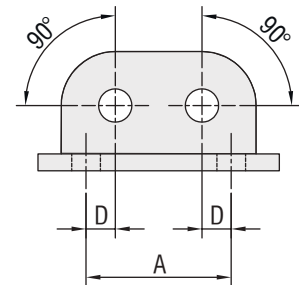
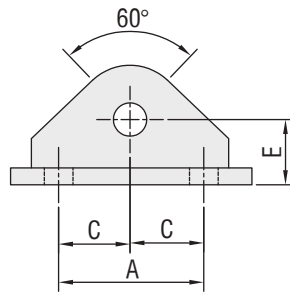
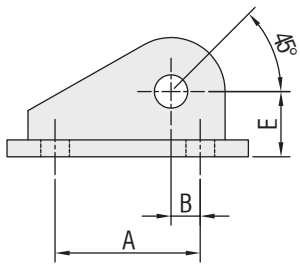

Chain Brackets are available both in MS and SS for fixing of Chains for Fenders / Fendering Systems in existing Wharf / Jetty or Structures. Chain Brackets are manufactured as per the requirement from 12 mm thickness to 75 mm thick Plates. Chain Brackets are supplied with Resin Capsule and Studs to fix them to the existing structures.

DIMENSION TABLE

ALL DIMENSIONS ARE IN MM.

ØH	A	B	C	D	E	BOLTS	Approx Weight	
							DCB A - B	DCB C
18	110	15	55	15	55	M16	7	8
20	110	15	55	15	55	M16	7	8
22	130	20	65	20	60	M20	10	12
24	130	20	65	20	60	M20	10	12
26	150	25	75	25	70	M24	15	18
28	160	25	80	25	80	M24	20	24
30	160	25	80	25	80	M24	20	24
32	190	35	95	35	90	M30	32	34
34	190	35	95	35	90	M30	32	34
36	210	35	105	35	95	M30	35	42
38	220	35	110	35	110	M36	50	55
40	220	35	110	35	110	M36	50	55
42	250	40	125	40	115	M36	62	72
44	260	40	130	40	120	M36	70	80
46	260	40	130	40	120	M42	70	80

DIMENSION AND WEIGHT MENTIONED ARE SUBJECT TO CHANGE WITHOUT NOTICE.

BOW SHACKLE

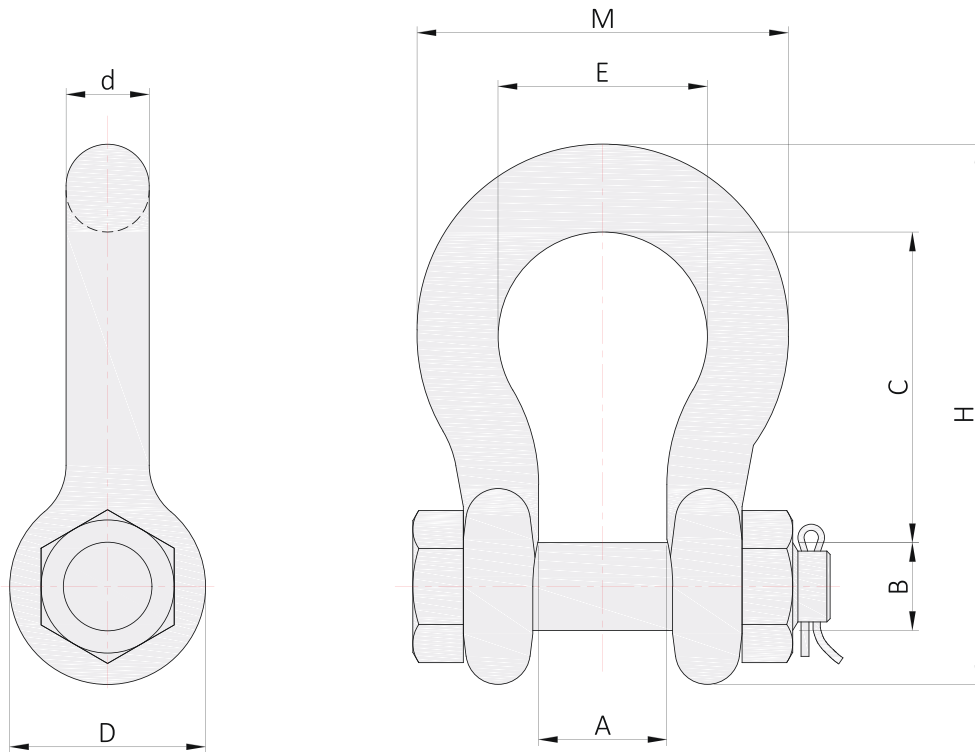

Nominal Size(mm)	A(mm)	B(mm)	C(mm)	d(mm)	E(mm)	D(mm)	H(mm)	M(mm)	Working Load Limit (Tonnes)	Approximate Weight Each (Kg)
4.8	9.7	6.4	22.4	4.8	15.3	14.2	37.3	24.9	0.3	0.03
6.4	11.9	7.9	28.7	6.4	19.8	15.5	46.7	32.5	0.5	0.05
7.9	13.5	9.7	31.0	7.9	21.3	19.1	53.1	37.3	0.7	0.10
9.5	16.8	11.2	36.6	9.7	26.2	23.1	63.2	45.2	1.0	0.15
11.1	19.1	12.7	42.9	11.2	29.5	26.9	73.9	51.6	1.5	0.22
12.7	20.6	16.3	47.8	12.7	33.3	30.2	83.3	58.7	2.0	0.36
15.9	26.9	19.6	60.5	16.0	42.9	38.1	106.4	74.7	3.2	0.76
19.1	31.8	22.6	71.4	19.1	50.8	46.0	126.2	88.9	4.7	1.23
22.2	36.6	25.9	84.1	22.4	57.9	53.1	148.1	102.4	6.5	1.79
25.4	42.9	29.2	95.3	25.4	68.3	60.5	166.6	119.1	8.5	2.57
28.6	46.0	31.8	108.0	28.7	73.9	68.3	189.7	131.1	9.5	3.75
31.8	51.6	35.6	119.1	32.8	82.6	76.2	209.6	146.1	12.0	5.31
34.9	57.2	38.9	133.4	36.1	92.2	84.1	232.7	162.1	13.5	7.18
38.1	60.5	42.2	146.1	38.9	98.6	92.2	254.0	174.8	17.0	8.61
44.5	73.2	51.8	177.8	46.7	127.0	106.4	313.4	223.5	25.0	15.38
50.8	82.6	58.4	196.9	52.8	146.1	122.2	347.5	257.8	35.0	23.70
63.5	104.9	71.1	266.7	68.8	184.2	144.5	454.7	323.9	55.0	44.56
76.2	127.0	83.8	330.2	79.2	200.1	165.1	546.1	371.3	85	69.85
88.9	133.4	95.5	371.6	91.9	228.6	203.2	632.0	432.3	120	120.20
101.6	139.7	108.2	368.3	101.6	254	228.6	652.3	457.2	150	153.31

DIMENSION AND WEIGHT MENTIONED ARE SUBJECT TO CHANGE WITHOUT NOTICE.

D SHACKLE WITH NUT - BOLT

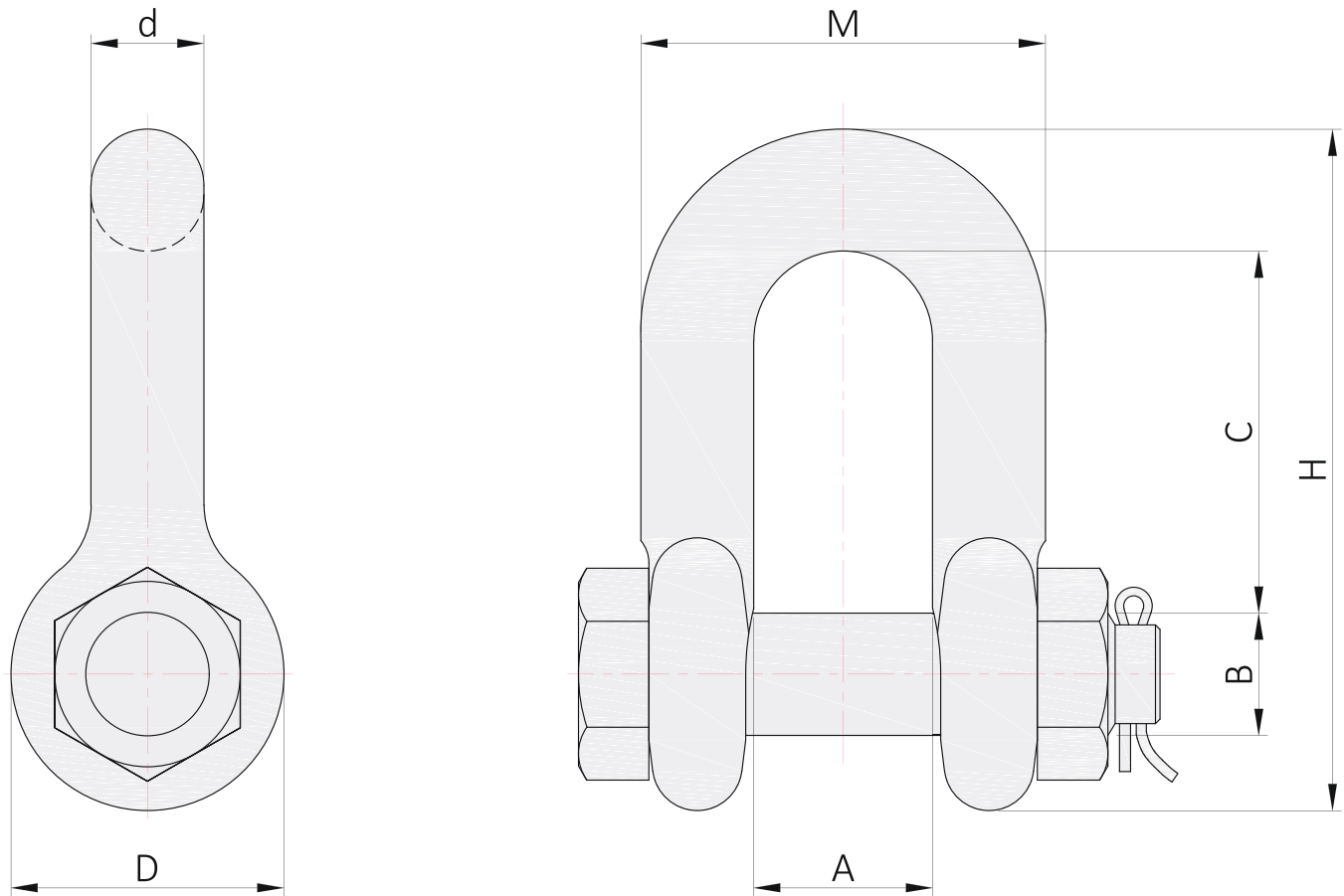

Nominal Size(mm)	A(mm)	B(mm)	C(mm)	d(mm)	D(mm)	M(mm)	H(mm)	Working Load Limit (Tonnes)	Approximate Weight Each (Kg)
6.4	12	7.8	23.1	6.4	15.7	24.6	40.4	0.5	0.06
7.9	13	9.6	27.2	7.9	19.1	29.2	48.5	0.7	0.10
9.5	17	11.1	32.5	9.7	23.4	36.1	58.7	1.0	0.15
11.1	19	12.7	37.6	11.2	26.9	41.4	67.8	1.5	0.22
12.7	21	16.2	42.2	12.7	30.0	46.0	77.0	2.0	0.34
15.9	27	19.5	51.8	16.0	38.1	58.9	95.5	3.2	0.67
19.1	32	22.6	61.0	19.1	46.0	69.9	115.1	4.7	1.14
22.2	37	25.9	72.6	22.4	55.9	81.3	135.4	6.5	1.75
25.4	43	29.2	82.3	25.4	60.5	93.7	150.9	8.5	2.52
28.6	46	31.7	91.7	28.7	68.1	103.4	172.2	9.5	3.44
31.8	52	35.5	100.8	31.8	76.2	115.1	190.5	12.0	4.90
34.9	57	38.8	112.5	35.1	84.1	127.3	210.3	13.5	6.24
38.1	60	42.1	123.7	38.1	91.9	136.7	229.9	17.0	8.39
44.5	73	51.8	147.8	44.5	106.4	160.0	278.6	25.0	14.24
50.8	83	58.4	173.2	53.3	127.0	184.2	323.6	35.0	21.20
63.5	105	71.1	205.0	66.8	144.3	238.3	377.2	55.0	38.55
76.2	127	82.5	217.4	76.2	165.1	279.4	428.5	85.0	56.35

DIMENSION AND WEIGHT MENTIONED ARE SUBJECT TO CHANGE WITHOUT NOTICE.

SCREW PIN D SHACKLE

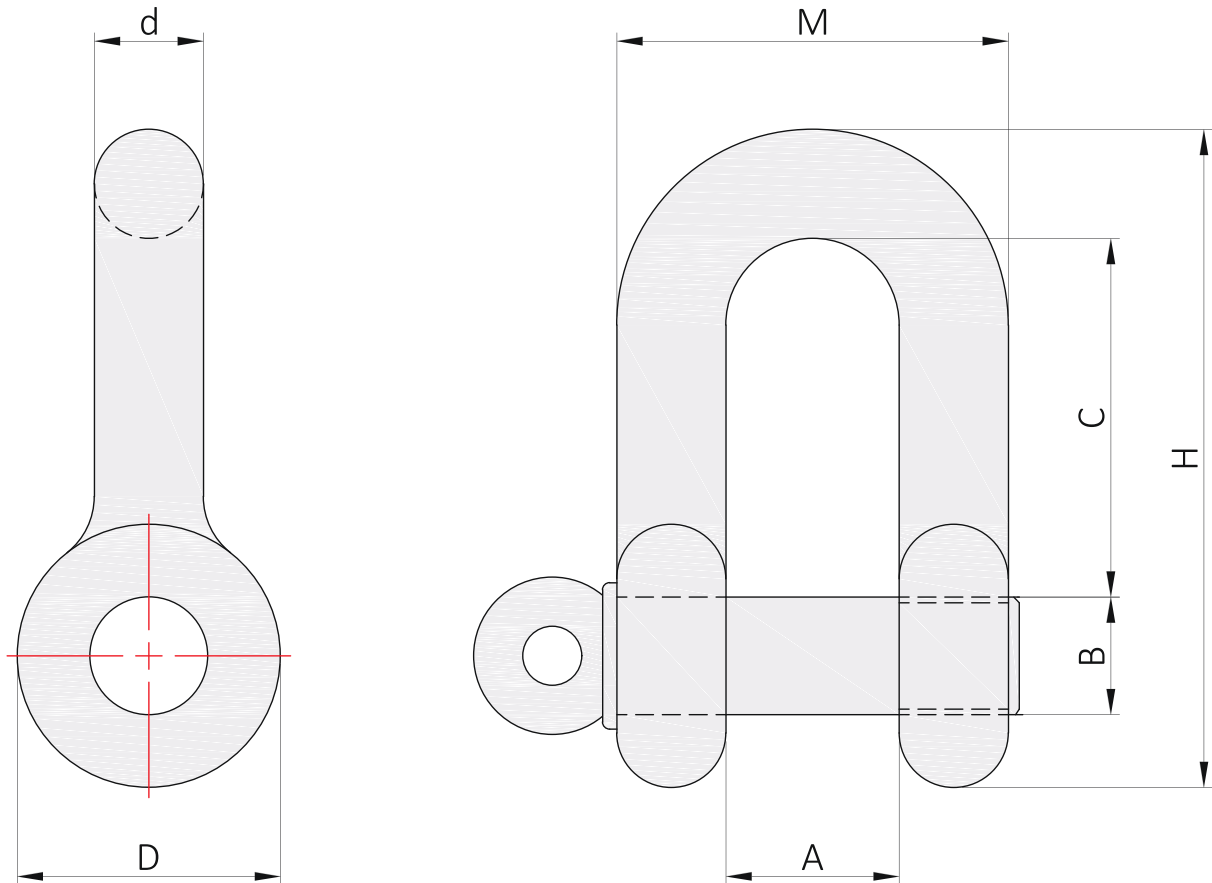

Nominal Size(mm)	DIMENSIONS in mm							Working Load Limit (Tonnes)	Approximate Weight Each (Kg)
	A(mm)	B(mm)	C(mm)	d(mm)	D(mm)	M(mm)	H(mm)		
6.4	11.9	7.9	22.4	6.4	15.5	24.6	40.4	0.5	0.05
7.9	13.5	9.7	26.2	7.9	19.1	29.5	48.5	0.8	0.08
9.5	16.8	11.2	31.8	9.7	23.1	35.8	58.4	1.0	0.11
11.1	19.1	12.7	36.6	11.2	26.9	41.4	67.6	1.5	0.18
12.7	20.6	16.0	41.4	12.7	30.2	46.0	77.0	2.0	0.27
15.9	26.9	19.1	50.8	16.0	38.1	58.7	95.3	3.3	0.55
19.1	31.8	22.4	60.5	19.1	46.0	69.9	115.1	5.0	1.02
22.2	36.6	25.4	71.4	22.4	53.1	81.0	135.4	6.5	1.43
25.4	42.9	28.7	81.0	25.4	60.5	93.7	150.9	8.5	2.15
28.6	46.0	31.8	90.9	28.7	68.3	103.1	172.2	9.5	3.06
31.8	51.6	35.1	100.1	31.8	76.2	115.1	190.5	12.0	4.11
34.9	57.2	38.1	111.3	35.1	84.1	127.0	210.3	13.5	5.28
38.1	60.5	41.1	122.2	38.1	91.9	136.7	230.1	17.0	7.23
44.5	73.2	53.8	146.1	44.5	106.4	162.1	278.6	25.0	12.13
50.8	82.6	50.8	171.5	50.8	122.2	184.2	311.9	32.0	19.19
63.5	104.9	66.5	203.2	66.5	144.5	238.3	376.9	55.0	32.55

DIMENSION AND WEIGHT MENTIONED ARE SUBJECT TO CHANGE WITHOUT NOTICE.

FLEX DRUM ASSEMBLY A SERIES

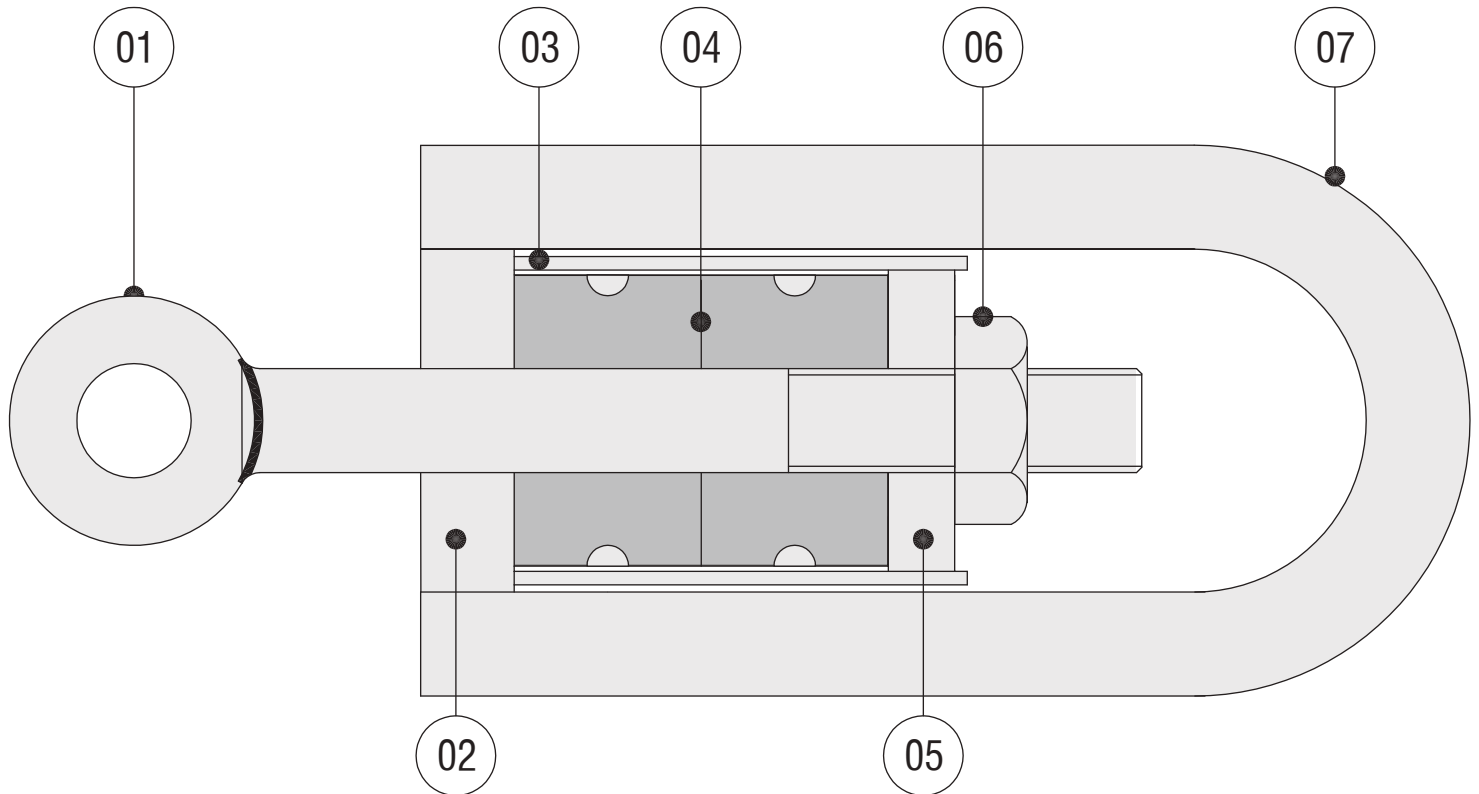

Flex Drum assemblies are provided to absorb sudden jerks and loads due to the pitching and rolling of vessels. The rubber cushion is necessary before passing on the load to the chain links. The material of construction is decided to suit specific customer needs and specifications.

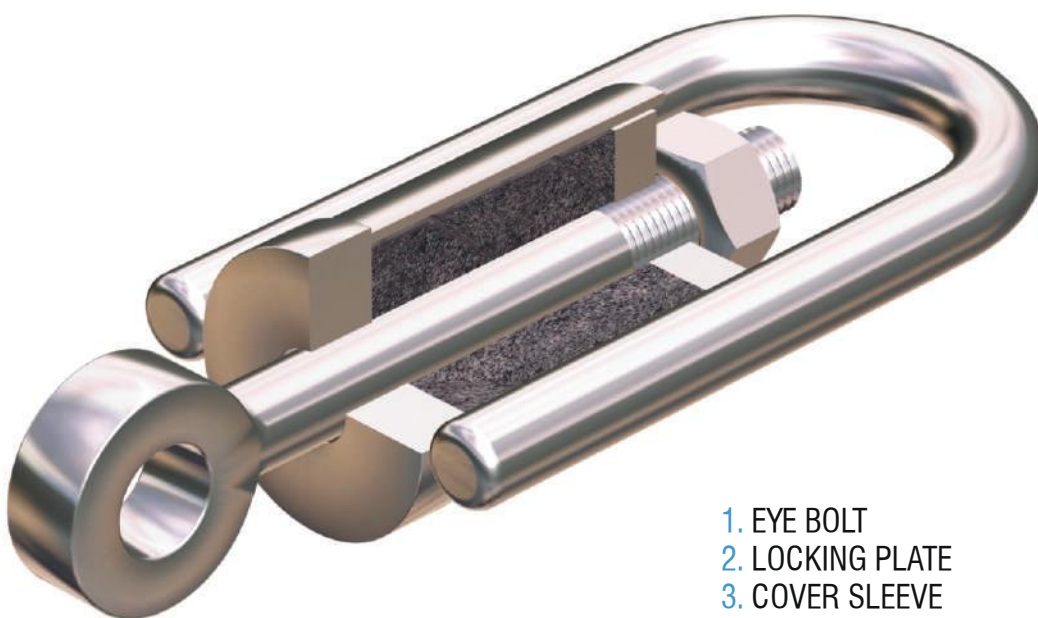

1. EYE BOLT
2. LOCKING PLATE
3. COVER SLEEVE
4. RUBBER PAD
5. CLOSURE PLATE
6. NUT
7. U HOOK

DESIGN MAY VARY AS PER SPECIFIC REQUIREMENT OF CLIENT.

FLEX DRUM ASSEMBLY B SERIES

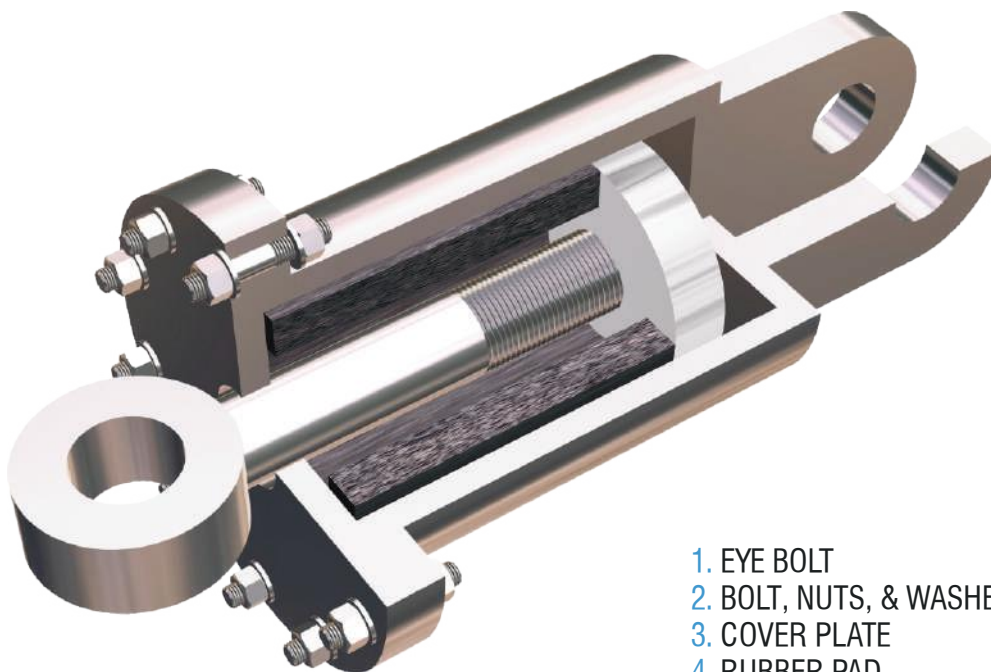
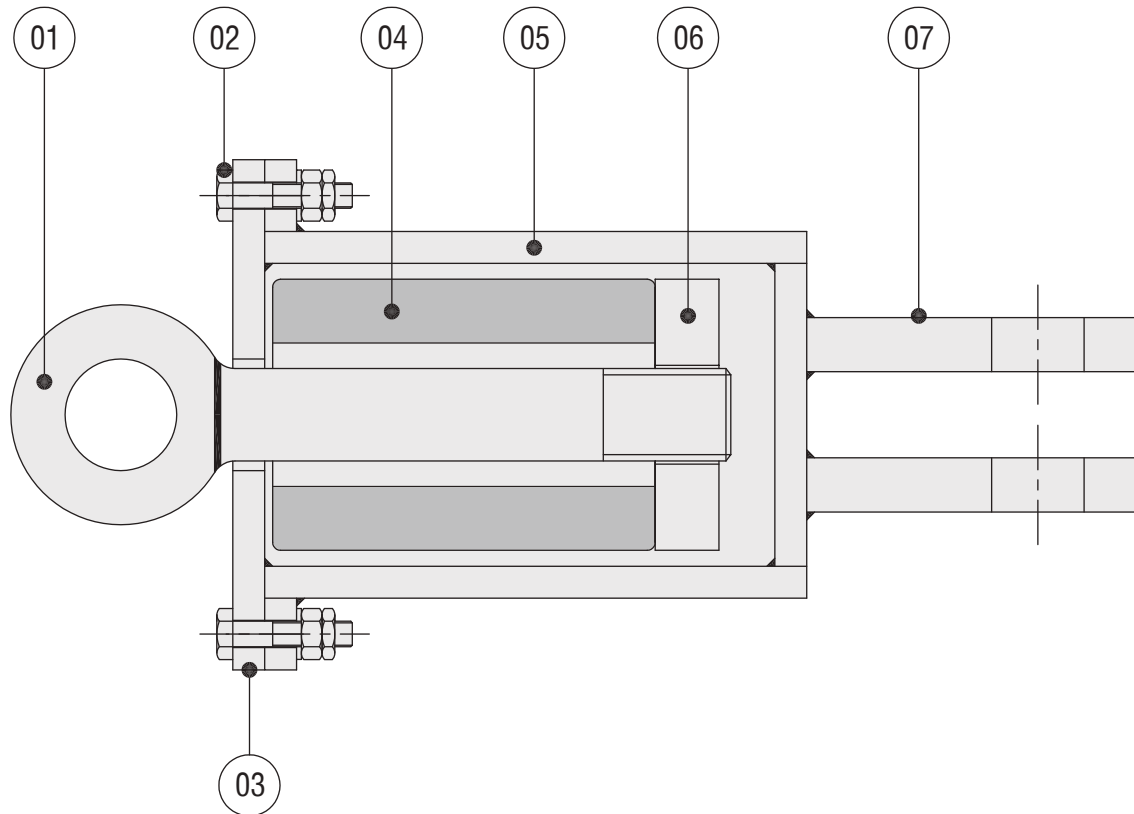

1. EYE BOLT
2. BOLT, NUTS, & WASHER
3. COVER PLATE
4. RUBBER PAD
5. OUTER SHELL
6. TAPPED ROUND NUT
7. D HOOKS

DESIGN MAY VARY AS PER SPECIFIC REQUIREMENT OF CLIENT.

ANCHOR BOLT SLEEVE TYPE

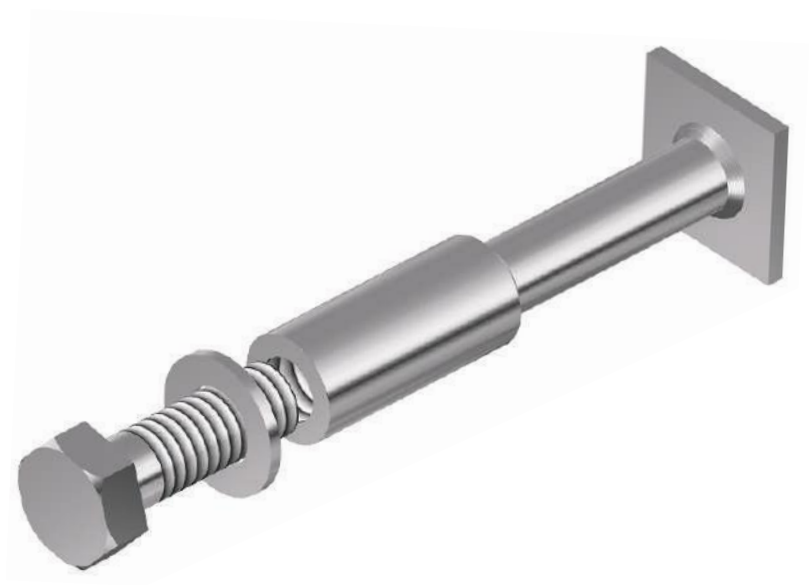
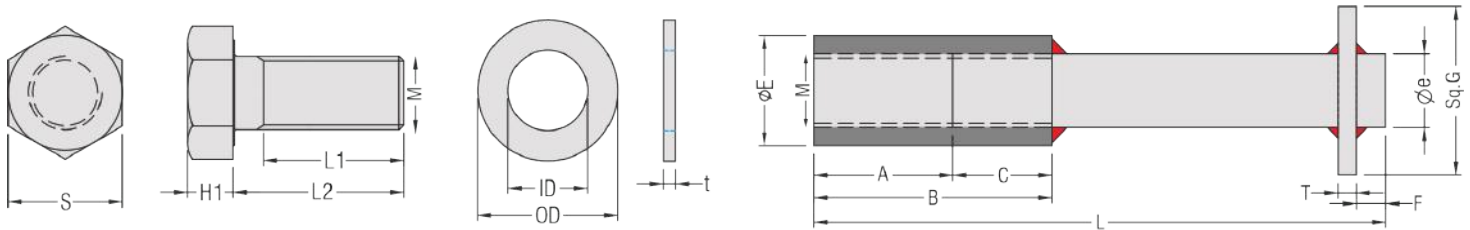

No.	PART	MATERIAL
1	SLEEVE	AVAILABLE IN DIFFERENT GRADE BOTH S.S/M.S
2	ANCHOR ROD	
3	ANCHOR PLATE	
4	BOLT	
5	WASHER (ROUND / SQUARE)	

Anchor Bolt assemblies are used to fix fenders onto wharfs or jetties that are under construction. An anchor Bolt assembly contains a single Fender fixing bolt, a single cast-in sleeve with a backside extension rod welded with end flange and a single loose washer matching the fender type. The sleeves are integrally cast with the structure to ensure maximum strength and can be supplied in MS galvanized or in SS as per specifications.

They are fixed with centring planks before casting the fender block, as per centre distances/template.

DIMENSION TABLE

ALL DIMENSIONS ARE IN MM

M	L	EMBEDDED PORTION							BOLT				ROUND WASHER			Total Weight (Kg)	
		A	B	C	ØE	Sq.G	T	F	Øe	S	H1	L1	L2	OD	ID		t
M20	175	45	65	20	26	65	6	10	20	30	13	46	55	40	22	3	0.83
M22	200	50	75	25	28	65	6	10	22	32	14	50	55	45	24	3	1.03
M24	210	55	80	25	32	70	6	10	24	36	15	54	60	50	26	4	1.34
M27	225	60	90	30	34	75	9	10	27	41	17	60	65	55	30	4	1.84
M30	250	65	95	30	38	75	9	10	30	46	19	66	70	60	33	4	2.36
M36	300	70	105	35	46	85	9	10	36	55	23	78	85	70	39	5	3.95
M42	350	75	115	40	55	90	12	15	42	65	26	82	90	80	45	6	6.24
M48	400	85	130	45	65	120	12	15	48	75	30	102	105	90	52	6	9.77
M56	450	90	145	55	75	125	16	15	56	85	35	115	120	105	62	8	15.04
M64	525	100	160	60	85	130	16	15	64	95	40	120	125	115	70	8	20.93
M76	575	120	195	75	100	150	20	20	76	110	48	160	165	135	82	10	33.59

THE ABOVE DIMENSION MAY VARY AS PER FENDER PROFILE ON CASE TO CASE BASIS

THE WEIGHT VALUES MENTIONED ARE APPROXIMATE

ANCHOR BOLT STUD TYPE

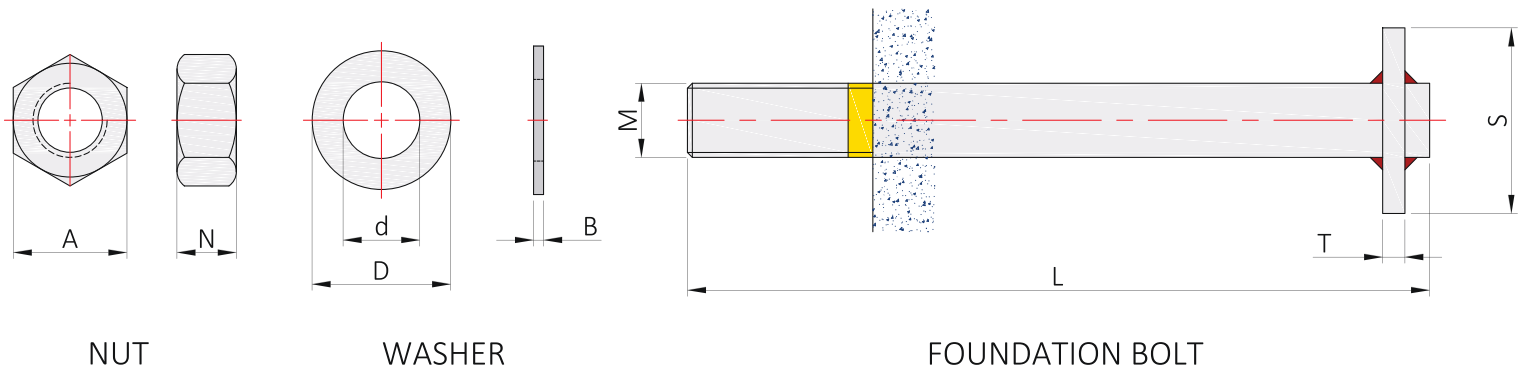

Anchor Bolts Stud type are used in new structures which are yet to be constructed. These are cast-in fixtures that are cast integrally with the structure during its construction. The Stud type Anchor Bolts are placed and fixed in the correct position with the help of the templates before concrete is poured. The Bolts should be firmly fixed so that their position should not change during concreting. Once the concrete is poured and cured, the Bolts are firmly integrated with the structure and ready for use.

DIMENSION TABLE

ALL DIMENSION ARE IN MM

BOLT		BACK PLATE		WASHER			NUT		Total Weight
Size	Length	SQ	T	OD	ID	T	AF	T	
M	L	S	T	D	d	B	A	N	Kg
M16	185	50	5	30	17	3	24	13	0.43
M20	225	65	6	40	22	3	30	16	0.83
M22	250	65	6	45	24	3	32	18	1.04
M24	250	70	6	50	26	4	36	19	1.26
M27	275	75	9	55	30	4	41	22	1.84
M30	300	75	9	60	33	4	46	24	2.34
M36	350	85	9	70	39	5	55	29	3.78
M42	450	90	12	80	45	6	65	34	6.46
M48	525	95	12	90	52	7	75	38	9.43
M56	600	100	16	105	62	8	85	45	14.56
M64	625	130	16	115	66	8	95	51	20.20
M76	825	150	20	135	82	10	110	64	36.64

THE ABOVE DIMENSIONS MAY VARY ON CASE TO CASE BASIS

THE WEIGHT VALUES MENTIONED ARE APPROXIMATE

RESIN ANCHOR BOLTS

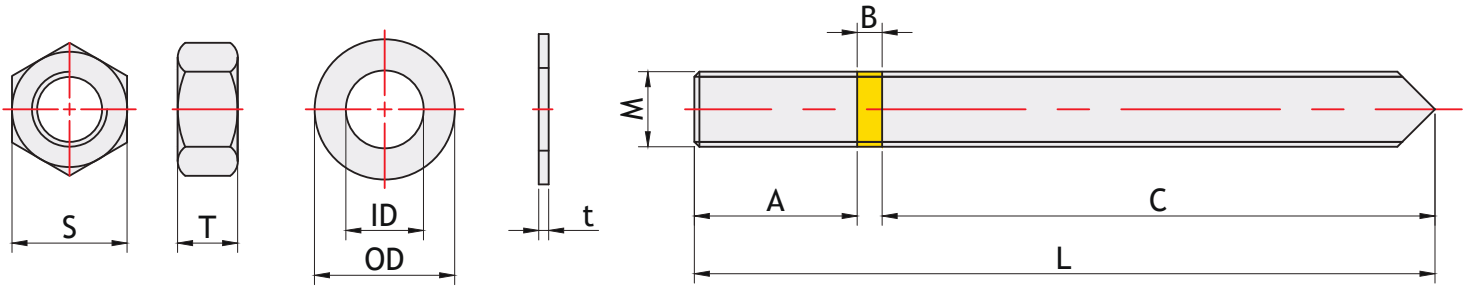

PART	MATERIAL
1. ANCHOR BOLT	AVAILABLE IN DIFFERENT GRADE OF S.S/M.S
2. NUT	
3. WASHER (ROUND / SQUARE)	
4. CAPSULE	TO SUIT THE BOLT SIZE HILTI, BOSCH OR EQUIVALENT

DIMENSION TABLE

ALL DIMENSION ARE IN MM

SIZE	ANCHOR STUD				NUT		ROUND WASHER			Total Weight
	A	B	C	L	S	T	OD	ID	t	
M8	20	10	95	125	13	6.5	18	9	1.5	0.06
M10	25	10	115	150	17	8	22	11	2	0.11
M12	30	10	135	175	19	10	27	14	2.5	0.18
M16	35	10	155	200	24	13	32	18	3	0.36
M20	45	10	180	235	30	16	40	22	3	0.66
M22	45	10	185	240	32	18	45	24	3	0.82
M24	50	10	190	250	36	19	50	26	4	1.03
M27	50	10	220	280	41	22	55	30	4	1.46
M30	55	10	235	300	46	24	60	33	4	1.94
M33	55	10	260	325	50	24	65	36	5	2.52
M36	65	10	275	350	55	29	70	39	5	3.27
M39	65	10	325	400	60	31	75	42	6	4.37
M42	75	10	365	450	65	34	80	45	6	5.67
M48	80	10	435	525	75	38	90	52	6	8.58
M56	100	10	490	600	85	45	105	62	8	13.31
M64	125	10	490	625	95	64	115	70	8	18.52
M76	150	10	690	850	110	76	135	82	10	34.55

NOTE : THE ABOVE DIMENSIONS MAY VARY ON CASE TO CASE BASIS.

THE WEIGHT VALUES MENTIONED ARE APPROXIMATE

FRAME FIXING BOLT

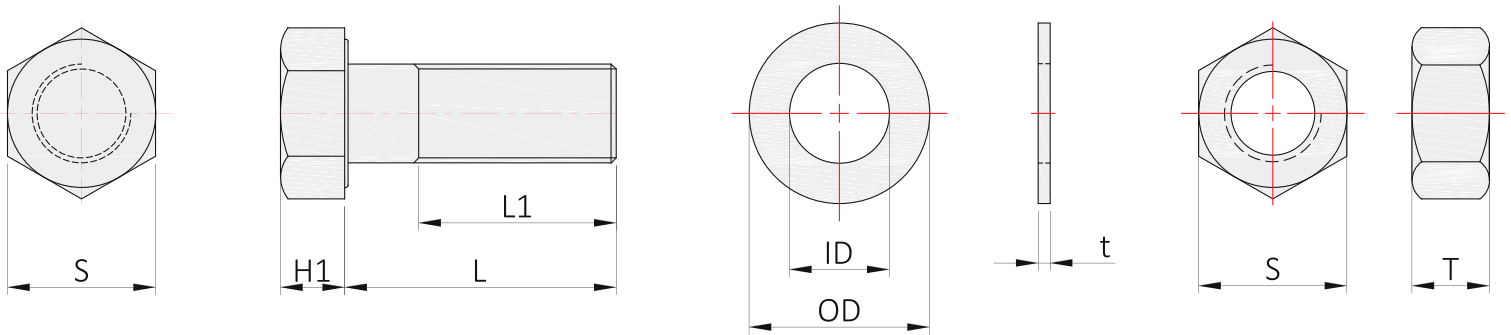

With Round washer

No.	PART	MATERIAL
1	BOLT	AVAILABLE IN DIFFERENT GRADE BOTH S.S/M.S
2	WASHER (Round / Rectangular)	
3	NUT	

DIMENSION TABLE

ALL DIMENSION ARE IN MM

MDØ	BOLT				ROUND WASHER			NUT		WEIGHT
	H1	S	L1	L	OD	ID	t	S	T	
M22	14	32	46	80	45	24	3	32	18	0.42
M24	15	36	54	85	50	26	4	36	19	0.57
M27	17	41	66	90	55	30	4	41	22	0.75
M30	19	46	70	100	60	33	4	46	24	1.06
M36	23	55	78	115	70	39	5	55	29	1.82
M42	26	65	90	130	80	45	6	65	34	2.79
M48	30	75	108	145	90	52	6	75	38	4.28
M56	35	85	120	160	105	62	8	85	45	6.57
M64	40	95	140	190	115	70	8	95	64	10.0
M76	48	110	175	215	135	82	10	110	76	16.0

DIMENSION MAY CHANGE ON CASE TO CASE BASIS

THE WEIGHT VALUES MENTIONED ARE APPROXIMATE

UHMW FACIA PADS

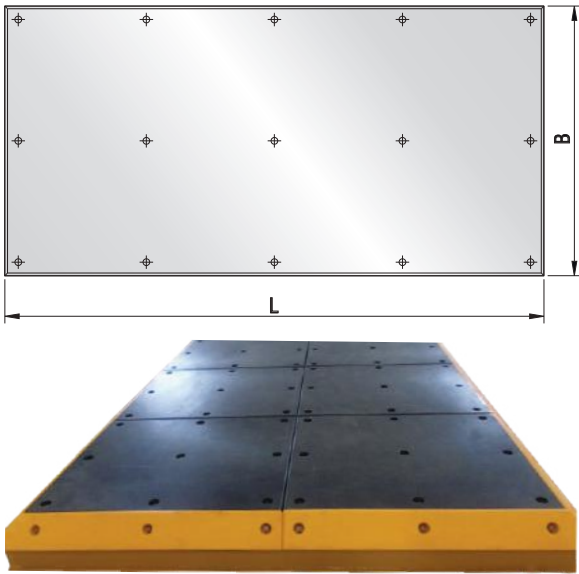

Facia Pads are made out of Ultra High Molecular Weight (UHMW), a Resin material with a very low friction coefficient. They offer excellent impact resistance, high abrasion resistance and high mechanical strength properties. They help to reduce the shear load transmitted to the structure. There is always a floating layer of oil/ grease/ diesel spill out from vessels, which can lead to hazardous sparking due to metal to metal rubbing; the Facia pad material, when rubbed with the Vessel hull, do not create any spark and prevent fire. This is the most versatile characteristic of Facia Pad, which makes its use UN-AVOIDABLE at Petroleum Berths. These Pads are also used as Dock Liners at small Ferry Wharf, Passenger Boats Jetties and Luxury Wharf to protect costly Ferries and Boats while berthing and offers a smooth surface and reduce friction and protect the hull of Ferries, Passenger Boats and Luxury Boats. Facia Pads / Dock Liners are available in a wide range in different thicknesses from 10 mm to 200mm and 200 MM Wide to 1500 mm Wide in required length up to 3 to 5 meters.

DIMENSION TABLE

STANDARD SHEETS SIZES FOR UHMW-PE

ALL DIMENSIONS ARE IN MM.

L	B	THICKNESS
2000	1000	10-200
2700	1300	10-60
3000	1220	15-150
4000	1330	15-140
5000	1250	15-70
6000	2000	30-120
6100	2000	15-120
6100	1220	15-120
10000	1000	15-70

OTHER THICKNESS ARE AVAILABLE ON SPECIFIC REQUIREMENT.
STANDARD TOLERANCE APPLY.

TECHNICAL SPECIFICATION UHMW PE PAD

UHMW PE Pads is impervious to common industrial chemicals and does not absorb water. This gives it the added advantage of a “non-stick”, “non-freeze” characteristic, and UHMW PE Pads does not become brittle even at sub-zero temperature.

Special Characteristics of Pads:

- High abrasion resistance.
- Ability to withstand sub-zero temperature.
- Excellent impact strength.
- Slippery Surface.
- Self Lubricating.
- Anti stick Properties.
- Good Chemical Resistance.
- No Water absorption.
- Non-Toxic.
- Good Machinability.

Physical properties of UHMW PE pad.

Item	Requirement	unit	Test Method
Density	0.93-0.96	g/cm ³	ISO 1183
Tensile Strength	> 18	N/mm ²	ISO 527-1
Breaking Strength	> 30	N/mm ²	ISO 527-1
Elongation at Break	> 100	% min	ISO 527-1
Temperature Range	-30 to 80	deg C	ISO 17025
Impact Strength	> 120	J/mm ²	ISO 179
Abrasion Resistance	90	Virgin UHMW PE= 100	SAND SLURRY
Shore D Hardness	65, +/- 3	Shore D	ISO 868
Coefficient of Friction	< 0.15		ISO 8295

STANDARD COLOUR OF THE “DIPTI” UHMW PE PADS WILL BE SKY-BLUE OR BLACK OR ORANGE. PADS IN OTHER COLOUR CAN ALSO BE MANUFACTURED TO SUITE SPECIFIC REQUIREMENTS.

EDGE PROTECTOR

Edge Protectors are used for preventing damages on a jetty edge which in the long run increases the substantial cost for the repair.

Key Attributes: High Mechanical Strength and Low friction, Easy to replace

Application: Used for protecting the edges of the jetty.

FOR EXISTING CONCRETE

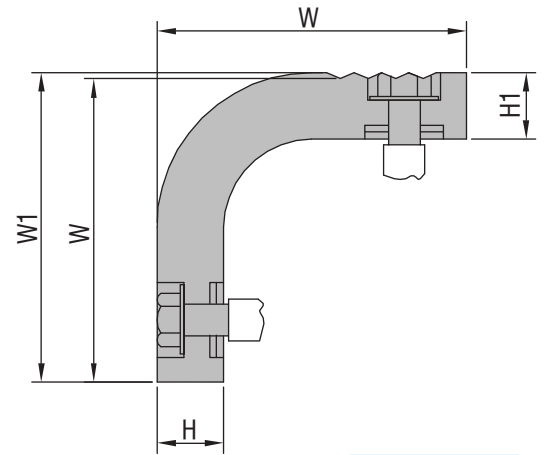
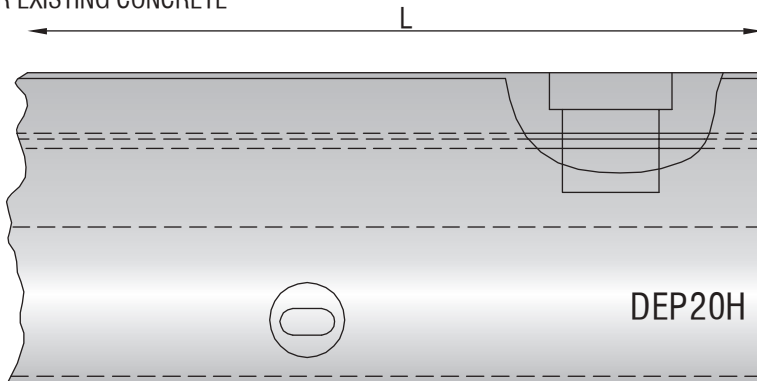

		DEP20H
DIMENSIONS (MM)	H	20
	W	100
	W1	102
	L	500-1000

		DEP20H
DIMENSIONS (MM)	H	20
	H1	22
	W	100
	W1	102
	L	500-1800

FOR NEW CONSTRUCTION

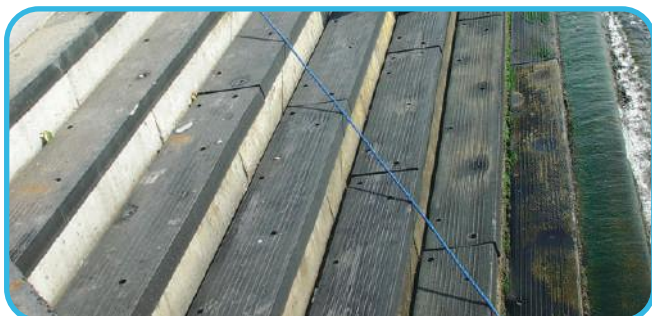
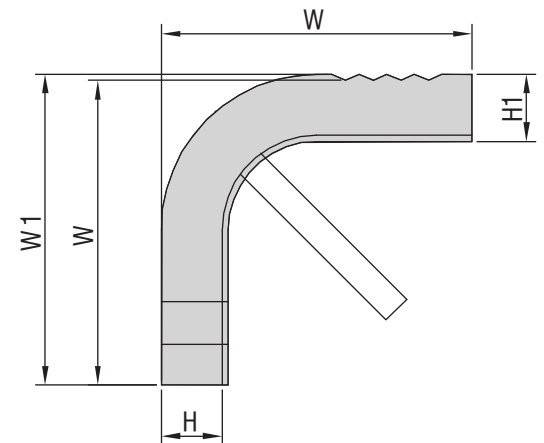
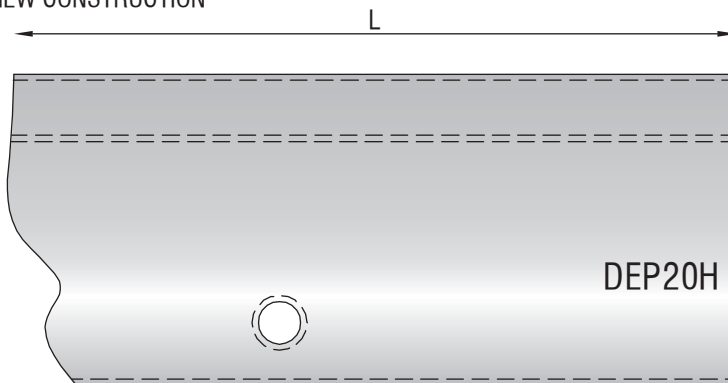

ALL DIMENSIONS ARE IN MM.
DIFFERENT LENGTHS, PROFILES ARE AVAILABLE ON SPECIFIC REQUIREMENT OF CLIENT.



MATERIAL
HIGH IMPACT & WEAR RESISTANT SYNTHETIC RESIN

IRM PRODUCTS WORLD WIDE

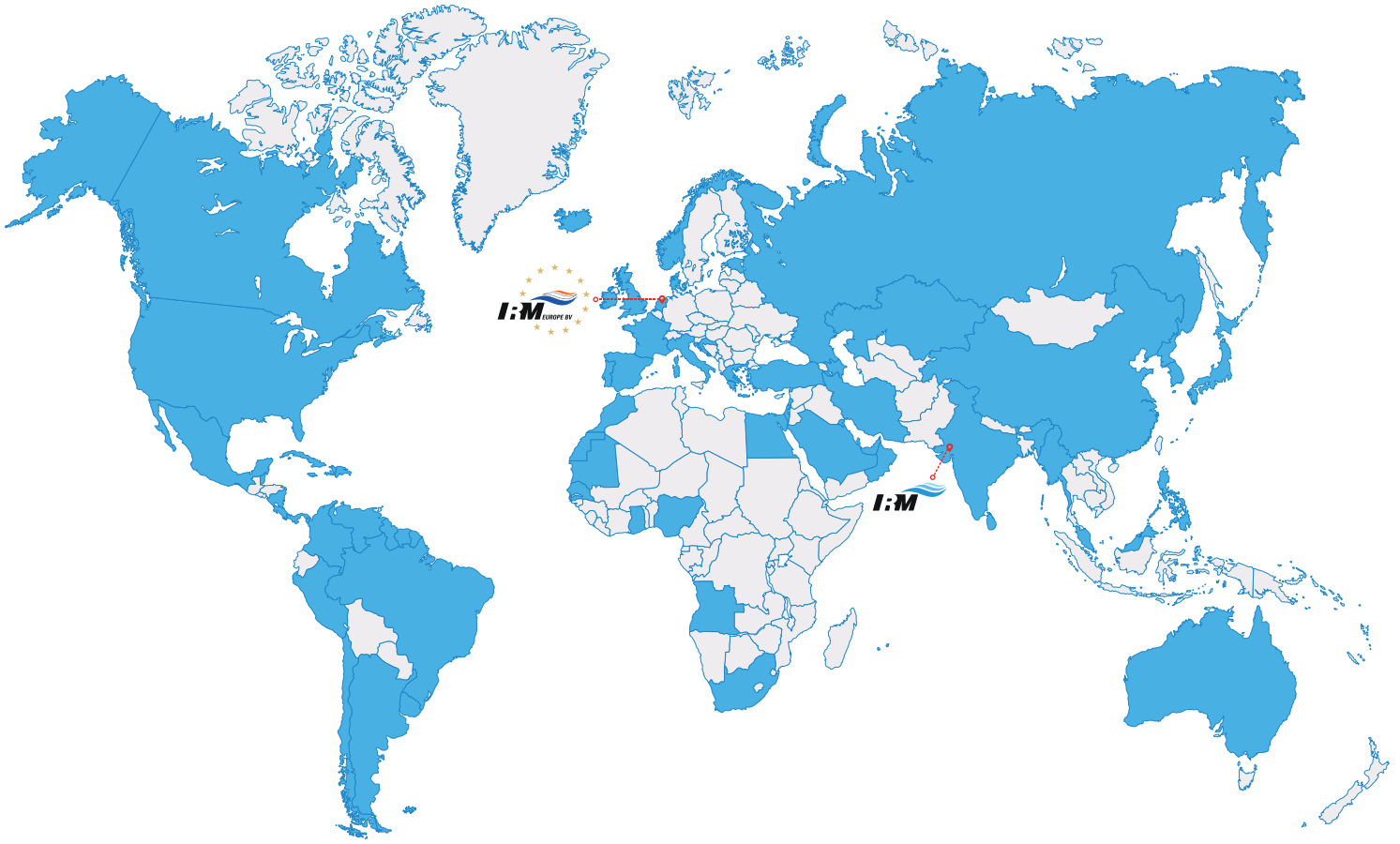

www.irmome.com

Block No. 707, Nandoli Road, Rancharda, Via Thaltej - Shilaj,
Ahmedabad - 382 115, Gujarat - India

M : +91 9825 067611 / +91 9727 738407

E : sales@irmome.com | marketing@irmome.com







www.irmeurope.com

Concordiastraat 84, 1951 AS Velsen-Noord, The Netherlands

M : +31 6268 93082 / +39 3355 648598

E : sales@irmeurope.com | marketing@irmeurope.com

Connect with us:

-  [irmome](#)
-  [irmome](#)
-  [irm-offshore-marine-engineers](#)
-  IRM Offshore and Marine Engineers IRMOME



DA R-09/2022

Total Solutions to Protect Your Structures