



CONE FENDERS

Founded in 1964 with modest beginnings, Industrial Rubber Moulders (IRM) manufactured rubber and allied articles for the textile, engineering, and mining industry. After more than five decades of consistent growth, IRM Offshore and Marine Engineers Private Limited is the flagship company of the IRM Group.

IRM offers more than 2,000 speciality rubber engineering products and various services for the shipbuilding industry, maritime infrastructure, offshore oil drilling platforms, wind mills and naval establishments. IRM offers a range of fenders that cater to the berthing requirements of a wide range of vessels used in today's maritime industry, from small tugboats to ultra-large crude carriers (ULCCs). This includes High performance fenders, Cone fenders, Cell fenders, Element fenders, etc. Multipurpose fenders like Cylindrical fenders, Arch fenders etc. Floating fenders like Pneumatic fenders, Foam fenders, Donut fenders etc. Moreover, IRM is a pioneer in manufacturing critical platform protection systems and offshore installation equipment such as diaphragm closures, grout seals, grout packers, pile grippers, platform protection systems, barge bumpers, shock cells and leg mating units for float overs.

IRM Offshore and Marine Engineers is an IMS (ISO 9001:2015, ISO 14001:2015 and ISO 45001:2018), certified company, A valid Manufacturers Capability Certificate (MCC) has been issued by BUREAU VERITAS.

IRM's state-of-the-art manufacturing facility and quality system are duly recognized by all prominent international third-party inspection agencies such as Lloyds, DNV, BVIS, EIL, IRS, MECON, and Velosi etc.

With our global headquarters and manufacturing plant in Ahmedabad – India, IRM also operates a technical sales, service support centre & a stockyard in The Netherlands - as 'IRM Europe BV', to provide better customer services in the European continent. IRM also has a network of 30 sales partners across the globe and supply references covering more than 80 countries.



IRM MANUFACTURING FACILITIES

IRM DCN Series Cone Fenders are compact fenders compared to Cell Fenders. They have a higher Energy Absorption capacity for the same height, which is mainly due to the conical shape, which allows deflection up to 72%. This advanced feature of Cone Fenders improves the material handling capabilities of the deck/vessel cranes and reduces the project's overall cost. Cone Fenders are also more stable at large compression angles and offer better shear resistance compared to any other fenders.

Like Cell Fenders, Cone Fenders can also be equipped with frontal frames fitted with low friction UHMW-PE fascia pads to reduce the shear force and the hull pressure. Cone Fenders can be installed in single, dual or in combination with a common frontal frame for optimizing the performance characteristics. These fenders are fitted with extended frames to provide a larger contact area vertically for ports with a high tidal variation.

KEY ATTRIBUTES

- Highly effective profile providing maximum efficiency
- Stable shape resists shear force
- Deflection up to 72%
- Can be reverse mounted for a smaller footprint
- Good Durability

RANGE

DCN Series Cone Fenders are available from 300 mm height to 2500 height and are supplied with suitable Frontal Frames and Chains.

APPLICATIONS

DCN Series Cone Fenders are found in various berthing applications and different types of construction

All types of berths and Jetties for following terminals.

- Container Terminals
- Bulk and General Cargo Terminals
- LNG, LPG & OIL Terminals
- RO-RO and Ro-Pax Terminals
- Other Marine Terminals

GENERAL FITTING ARRANGEMENTS

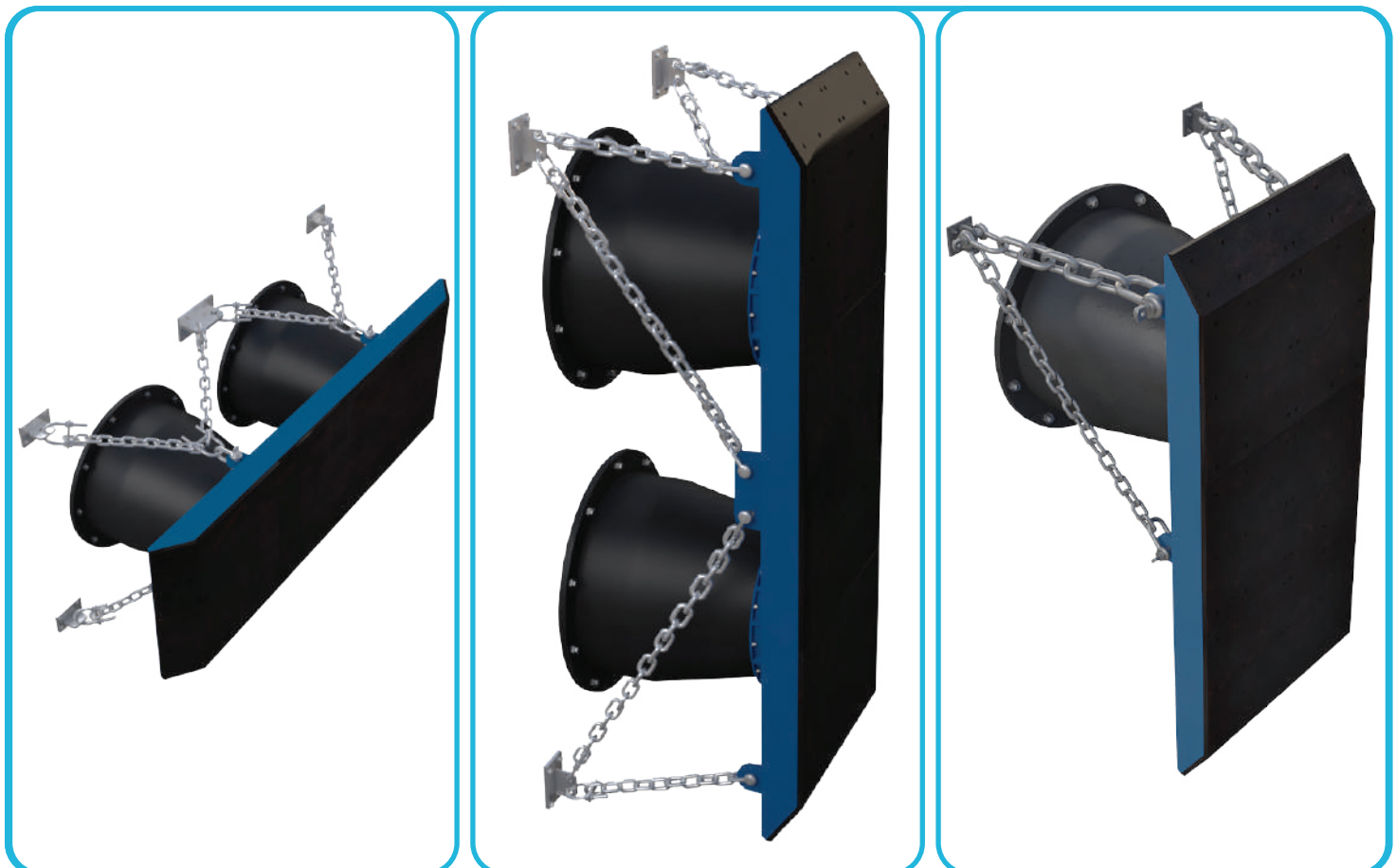

DIMENSION TABLE

ALL DIMENSIONS ARE IN MM

MODEL	A	ØB	ØC	ØD	ØE	F & G		T	APPROX WEIGHT Kgs
						BOLT FOR	BOLT FOR		
						R1 TO R2,3	R3 TO R4		
DCN 300H	300	500	295	440	255	4 x M16	4 x M16	15	35
DCN 350H	350	570	330	510	275	4 x M16	4 x M16	15	45
DCN 400H	400	650	390	585	340	4 x M20	4 x M16	20	75
DCN 500H	500	800	490	730	425	4 x M24	4 x M20	25	145
DCN 550H	550	880	540	790	470	4 x M24	4 x M20	25	195
DCN 600H	600	960	590	875	515	4 x M30	4 x M20	30	250
DCN 700H	700	1120	685	1020	600	4 x M30	4 x M24	35	400
DCN 800H	800	1280	785	1165	685	6 x M30	6 x M24	35	610
DCN 900H	900	1440	885	1313	770	6 x M30	6 x M30	35	850
DCN 1000H	1000	1600	980	1460	855	6 x M36	6 x M30	35	1125
DCN 1050H	1050	1680	1030	1530	900	6 x M36	6 x M30	40	1365
DCN 1100H	1100	1760	1080	1605	940	8 x M36	8 x M30	40	1550
DCN 1200H	1200	1920	1175	1750	1025	8 x M42	8 x M36	40	1975
DCN 1300H	1300	2080	1275	1900	1100	8 x M42	8 x M36	40	2460
DCN 1400H	1400	2240	1370	2040	1195	8 x M42	8 x M36	50	3110
DCN 1600H	1600	2560	1570	2335	1365	8 x M48	8 x M42	60	4650
DCN 1800H	1800	2880	1765	2625	1540	10 x M56	10 x M48	60	6620
DCN 2000H	2000	3200	1955	2920	1710	10 x M56	10 x M48	90	9560
DCN 2250H	2250	3600	2205	3285	1930	12 x M56	12 x M48	105	13500
DCN 2500H	2500	4000	2450	3650	2150	12 x M64	12 x M56	120	18500

Note : Weight values mentioned are approximate.

SCHEMATIC DIAGRAM

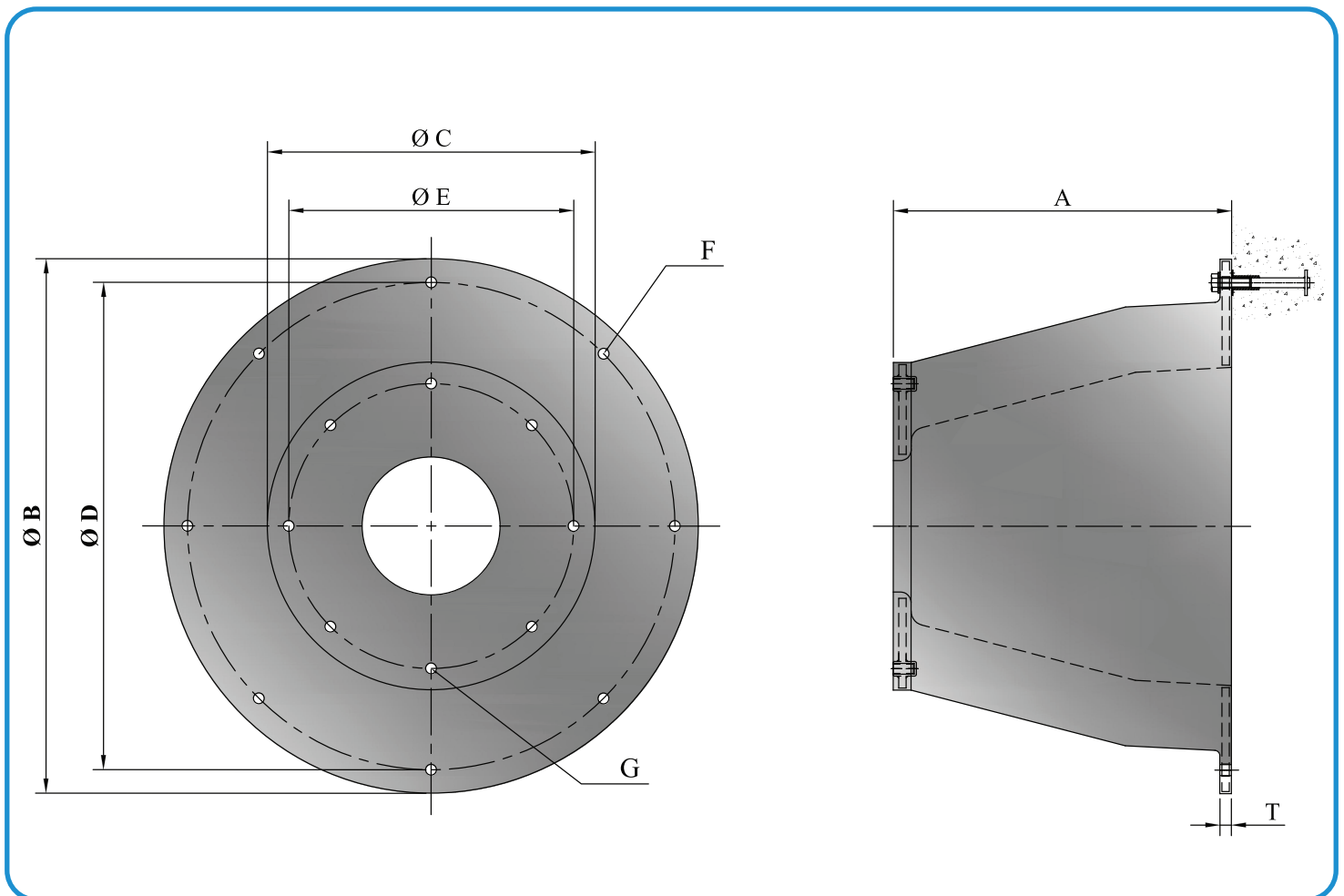

PERFORMANCE TABLE

MODEL	DEFLECTION	R1		R1.1		R1.2		R1.3		R2		R2.1		R2.2	
		E	R	E	R	E	R	E	R	E	R	E	R	E	R
DCN 300H	72.0%	19.6	110.8	18.6	105.9	17.6	101.0	16.6	94.1	15.6	87.2	14.7	81.4	13.7	75.5
DCN 350H	72.0%	31.3	151.0	30.4	144.1	28.4	138.2	26.4	127.4	24.5	117.6	23.5	110.8	21.5	102.9
DCN 400H	72.0%	47.0	199.0	45.1	190.2	43.1	181.4	40.2	167.6	37.2	154.9	34.3	145.1	32.3	135.3
DCN 500H	72.0%	93.1	310.8	88.2	297.1	84.3	282.4	78.4	262.8	72.5	243.2	67.6	227.5	63.74	211.8
DCN 550H	72.0%	123.5	374.6	117.6	357.9	111.8	341.2	103.9	316.7	96.1	293.2	90.2	274.5	84.3	255.9
DCN 600H	72.0%	158.8	442.2	151.0	421.6	144.1	402.0	132.3	368.7	119.6	334.4	110.8	307.9	101.0	281.4
DCN 700H	72.0%	251.0	601.1	240.2	573.6	228.4	547.2	212.8	508.9	197.1	470.7	184.3	441.3	172.6	411.8
DCN 800H	72.0%	382.4	799.2	364.8	762.9	347.1	726.6	321.6	673.7	297.1	620.7	276.5	579.5	256.9	537.4
DCN 900H	72.0%	542.3	1008.1	517.7	962.0	493.2	916.9	456.0	848.2	419.7	779.6	390.3	726.6	361.8	672.7
DCN1000H	72.0%	745.3	1246.4	710.9	1190.5	677.6	1133.6	626.6	1049.3	576.6	964.9	537.4	899.2	498.1	833.5
DCN 1050H	72.0%	862.0	1373.9	822.7	1311.1	783.5	1248.3	725.6	1156.2	667.8	1064.0	621.7	991.4	576.6	918.8
DCN1100H	72.0%	989.4	1505.3	944.3	1436.6	899.2	1369.0	833.5	1268.0	767.8	1167.9	715.8	1089.5	663.9	1011.0
DCN 1200H	72.0%	1285.6	1793.6	1227.7	1712.2	1168.9	1630.8	1083.6	1511.2	998.3	1391.5	931.6	1298.4	864.9	1205.2
DCN1300H	72.0%	1636.7	2106.4	1562.2	2010.3	1487.6	1915.2	1376.8	1773.0	1267.0	1630.8	1180.7	1519.0	1094.4	1408.2
DCN 1400H	72.0%	2044.6	2443.8	1952.5	2333.0	1859.3	2222.1	1721.0	2057.4	1582.7	1892.6	1475.9	1764.2	1368.0	1635.7
DCN 1600H	72.0%	3049.8	3190.1	2911.5	3044.9	2773.3	2899.8	2567.3	2685.0	2361.4	2470.3	2201.5	2302.6	2041.7	2134.9
DCN 1800H	72.0%	4349.2	4043.2	4152.1	3859.9	3954.0	3675.5	3660.8	3402.9	3367.6	3131.2	3139.1	2918.4	2910.6	2705.6
DCN 2000H	72.0%	5943.8	4972.9	5674.1	4747.4	5404.4	4521.8	5002.3	4185.4	4600.3	3849.1	4286.4	3586.2	3972.6	3323.4
DCN 2250H	72.0%	8879.9	6637.1	8475.8	6335.1	8072.8	6033.0	7668.8	5731.0	7264.7	5428.9	6860.7	5127.9	6456.7	4825.8
DCN 2500H	72.0%	12181.8	8159.1	11627.7	7788.4	11073.6	7416.7	10519.5	7046.0	9965.5	6675.3	9411.4	6303.7	8857.3	5933.0

Note : Intermediate performance with similar E/R ratio are available in between grades.

(R: REACTION FORCE (KN) , E: ENERGY ABSORPTION (KNM), TOLERANCE ±10%.)

PERFORMANCE CURVE

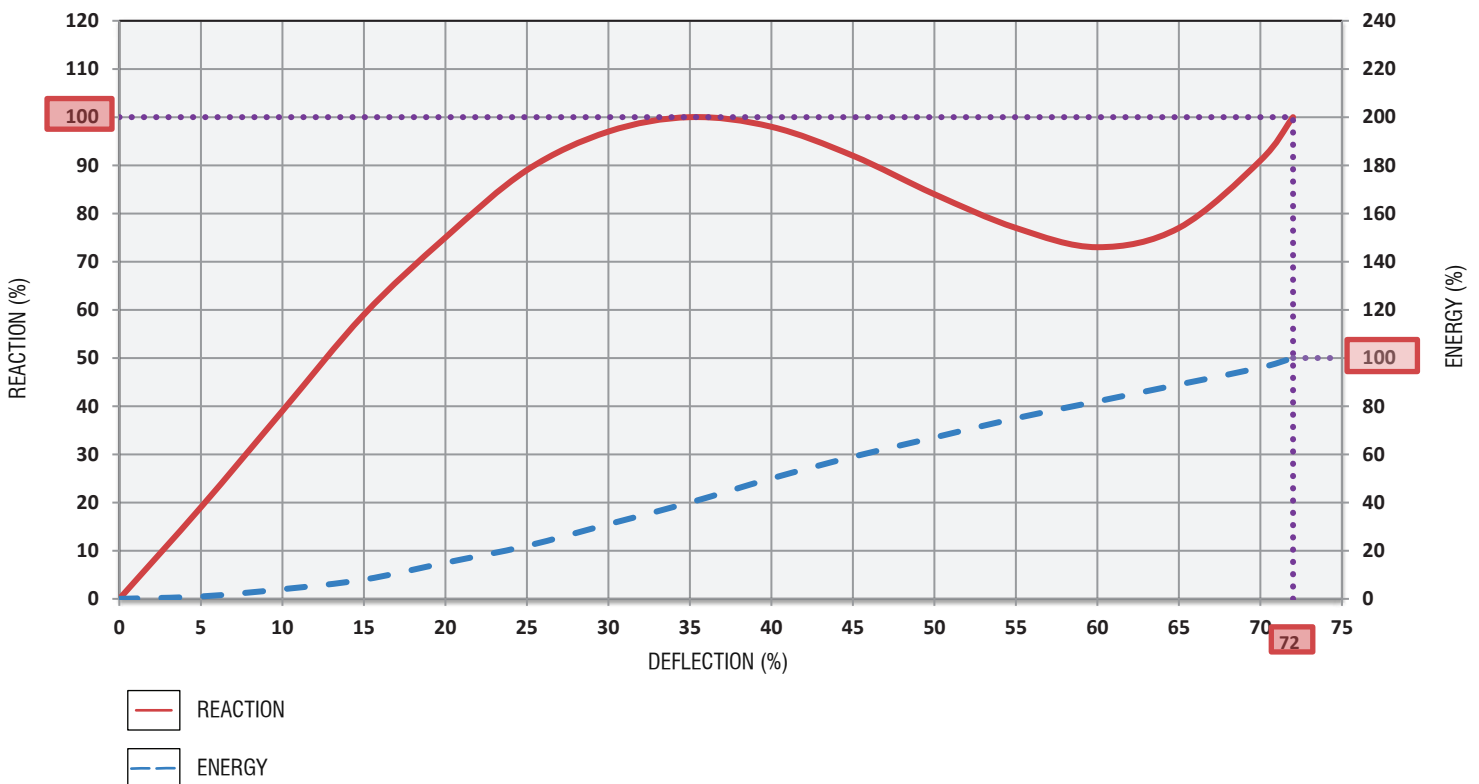

E (%)	0	1	4	8	15	22	31	40	50	59	67	75	82	89	96	100
R (%)	0	20	39	58	76	90	98	100	96	94	90	88	88	90	96	100
D (%)	0	5	10	15	20	25	30	35	40	45	50	55	60	65	70	72

Performance Curve indicates generic geometry and may vary depending on Grade, Site & berthing condition.

PERFORMANCE TABLE

MODEL	DEFLECTION	R2.3		R3		R3.1		R3.2		R3.3		R4	
		E	R	E	R	E	R	E	R	E	R	E	R
DCN 300H	72.0%	12.7	69.6	11.7	62.7	10.7	58.8	9.8	53.9	8.8	50.9	8.8	49.0
DCN 350H	72.0%	19.6	94.1	17.6	86.3	16.6	80.4	15.6	73.5	14.7	70.6	13.7	66.6
DCN 400H	72.0%	29.4	123.5	27.4	112.7	25.5	104.9	23.5	97.0	21.5	92.1	20.5	87.2
DCN 500H	72.0%	57.8	194.1	52.9	176.5	49.0	164.7	45.1	152.0	43.1	144.1	41.1	137.2
DCN 550H	72.0%	77.4	235.3	70.6	213.7	65.7	198.0	59.8	183.3	56.8	173.5	53.9	164.7
DCN 600H	72.0%	93.1	260.8	86.3	240.2	80.4	224.5	75.5	209.8	71.5	199.0	67.6	189.2
DCN 700H	72.0%	159.8	381.4	147.1	352.0	138.2	331.4	130.4	310.8	123.5	295.1	116.7	279.4
DCN 800H	72.0%	237.3	497.2	218.6	456.9	204.9	427.5	190.2	399.1	181.4	378.5	171.6	358.9
DCN 900H	72.0%	336.3	625.6	310.8	577.6	293.2	545.2	275.5	512.8	261.8	487.3	248.1	461.8
DCN1000H	72.0%	461.8	772.7	425.6	712.9	401.0	671.7	376.5	629.5	357.9	598.2	338.3	566.8
DCN 1050H	72.0%	535.4	853.1	493.2	786.4	464.8	740.4	436.4	694.3	413.8	659.9	392.2	625.6
DCN1100H	72.0%	615.8	937.5	567.8	863.9	533.4	811.9	500.1	761.0	474.6	722.7	450.1	684.5
DCN 1200H	72.0%	802.1	1117.9	739.4	1030.6	695.2	969.8	651.1	909.0	618.8	862.9	586.4	817.8
DCN1300H	72.0%	1014.9	1307.2	936.5	1205.2	881.6	1134.6	826.7	1064.0	785.5	1011.0	744.3	958.1
DCN 1400H	72.0%	1269.9	1517.0	1170.9	1399.4	1102.2	1317.0	1032.6	1234.6	981.6	1172.8	929.6	1112.0
DCN 1600H	72.0%	1893.6	1979.9	1745.5	1825.0	1641.6	1716.1	1536.7	1607.3	1460.2	1526.9	1382.7	1446.4
DCN 1800H	72.0%	2699.7	2509.5	2487.9	2313.3	2340.8	2176.1	2192.7	2037.8	2082.9	1936.8	1973.1	1834.8
DCN 2000H	72.0%	3686.3	3084.1	3399.9	2844.9	3199.9	2677.2	3000.1	2510.5	2849.8	2384.9	2699.7	2259.4
DCN 2250H	72.0%	6052.6	4523.8	5648.6	4221.7	5244.6	3919.7	4841.5	3618.6	4437.5	3316.6	4033.4	3014.5
DCN 2500H	72.0%	8303.2	5561.3	7749.2	5190.6	7196.1	4819.9	6642.0	4448.3	6087.9	4077.6	5533.8	3705.9

Note : Intermediate performance with similar E/R ratio are available in between grades.

(R: REACTION FORCE (KN) , E: ENERGY ABSORPTION (KNM), TOLERANCE +10%.)

CORRECTION FACTORS

ENERGY

Velocity Correction Factor-Energy Absorption	
Berthing Velocity (M/sec)	Correction Factor-Energy Absorption
0.001	0.896
0.050	0.981
0.100	0.992
0.150	1.000
0.200	1.001
0.250	1.004
0.300	1.008

Temperature Correction Factor-Energy Absorption	
Temperature (Deg C)	Energy Absorption Correction Factor
-30	1.102
-20	1.092
-10	1.037
0	1.011
10	1.006
20	1.003
23	1.000
30	0.936
40	0.963
50	0.952

Angular Correction Factor - Energy Absorption	
Berthing Angle(Degree)	Energy Absorption Correction Factor
0	1.000
3	1.062
5	1.047
8	1.022
10	1.011
15	0.981
20	0.933

REACTION

Velocity Correction Factor-Reaction Force	
Berthing Velocity (M/sec)	Correction Factor-Reaction Force
0.001	0.904
0.050	0.990
0.100	0.998
0.150	1.000
0.200	1.002
0.250	1.005
0.300	1.009

Temperature Correction Factor-Reaction Force	
Temperature (Deg C)	Reaction Correction Factor
-30	1.093
-20	1.059
-10	1.049
0	1.043
10	1.034
20	1.018
23	1.000
30	0.984
40	0.947
50	0.947

- Fender Testing Reference :
PIANC - Guideline for the design of Fenders System.
- Test Protocol :
1) CV Method
2) DV Method
- Rated Performance is referred to
Temperature : 23^o C ± 5^o C
Velocity : 0.15 meter/sec
Angle : 0 degree deflection
- Correction Factors are accorded to PIANC Guideline and needed to apply during design & verification of performance test.



IRM PRODUCTS WORLD WIDE

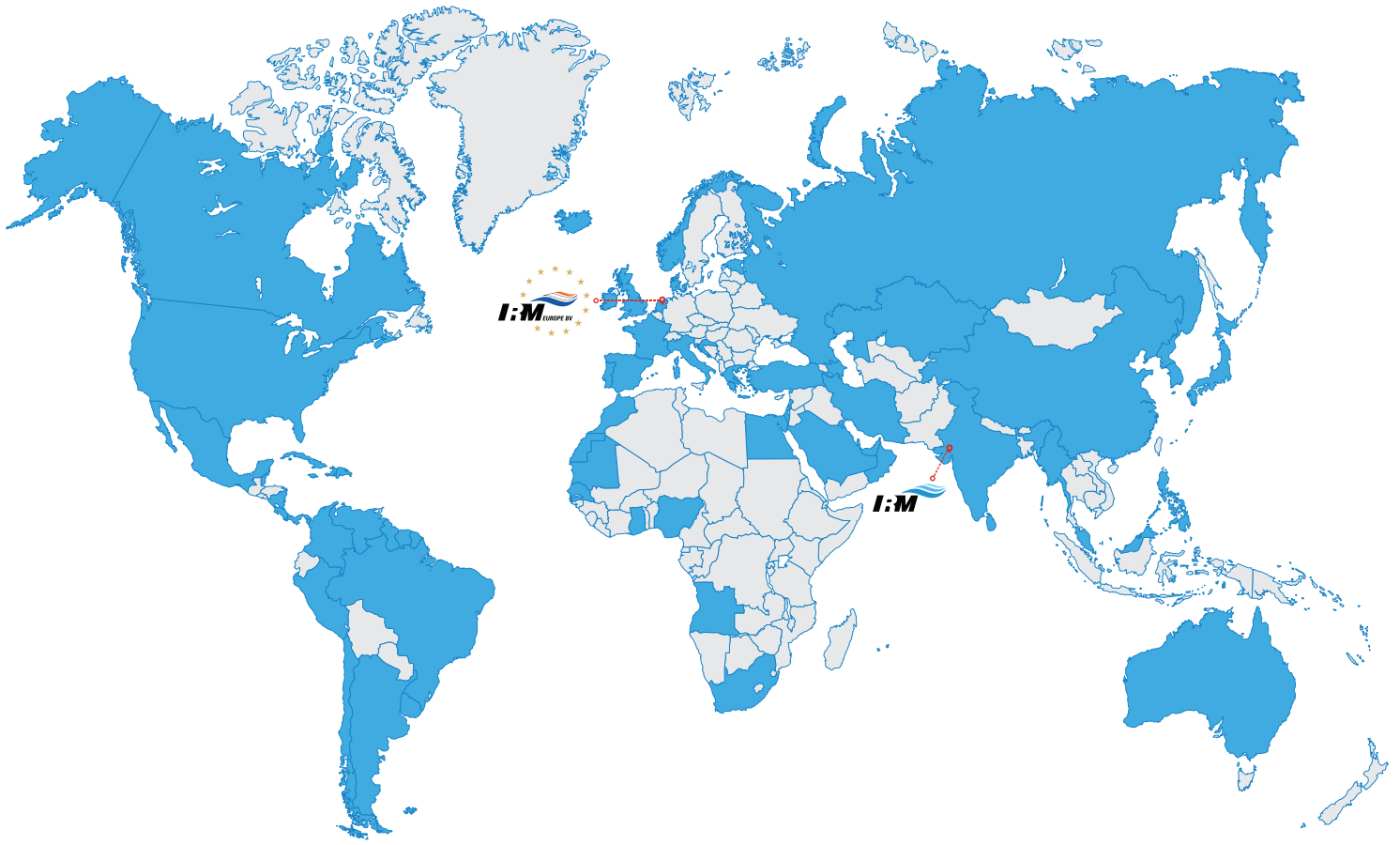

www.irmome.com

Block No. 707, Nandoli Road, Rancharda, Via Thaltej - Shilaj,
Ahmedabad - 382 115, Gujarat - India

M : +91 9825 067611 / +91 9727 738407

E : sales@irmome.com | marketing@irmome.com







www.irmeurope.com

Concordiastraat 84, 1951 AS Velsen-Noord, The Netherlands

M : +31 6268 93082 / +39 3355 648598

E : sales@irmeurope.com | marketing@irmeurope.com

Connect with us:

-  [irmome](#)
-  [irmome](#)
-  [irm-offshore-marine-engineers](#)
-  [IRM Offshore and Marine Engineers IRMOME](#)



Total Solutions to Protect Your Structures